

RoHS

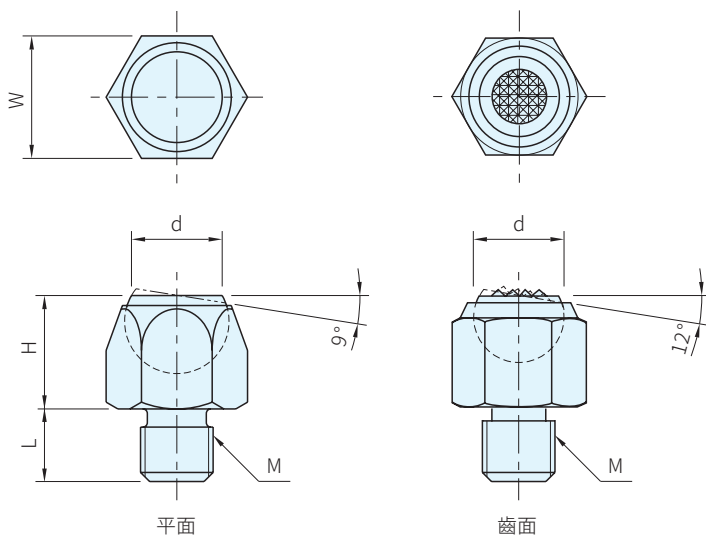

Type	本體		珠子	
	材質	處理	材質	硬度
平面	S45C	染黑	SUJ2	HRC56~67
齒面	SCM435	熱處理		HRC50~55

品號	型式	M	L	H	d	W	許容荷重 KN	質量 g	庫存
BJ730-04006	平面	M4×0.7	5	6	4.5	7	5.5	2	△
BJ730-05008		M5×0.8	6	8	6	8	9	4	△
BJ730-06009		M6×1	7	9	7.4	10	13.7	12	△
BJ730-08012		M8×1.25	9	12	10.5	13	25.6	15	△
BJ730-10016		M10×1.5	11	16	12.7	17	40	45	△
BJ730-12020		M12×1.75	12	20	15	22	59.4	50	△
BJ730-16025		M16×2	16	25	20	27	96.4	115	△
BJ730-20032		M20×2.5	20	30	22	32	100	200	△
BJ730-06113	齒面	M6×1	7	13±0.25	6.7	13	10	15	△
BJ730-08113		M8×1.25	8					20	△
BJ730-10118		M10×1.5	10	18±0.25	10	19	25	35	△
BJ730-12118		M12×1.75	12					45	△
BJ730-16127		M16×2	16	27±0.25	20	30	90	160	△
BJ730-20127		M20×2.5	20					180	△

Ex. 使用例

訂貨：  交期：  天

BJ730-06009

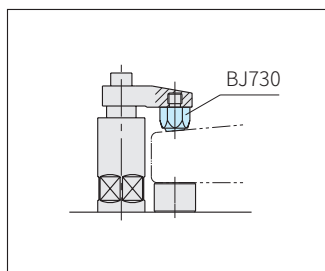

裝置在夾具上