

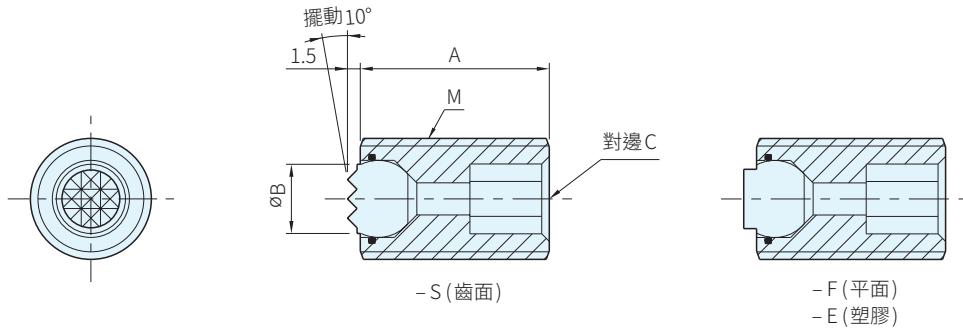

名稱	材質	處理	硬度	顏色
本體	SCM440	染黑	-	-
珠子(齒面)	SKH51		HRC60	-
珠子(平面)		POM	-	-
珠子(塑膠)	-		-	白



品號	A	B	C	M	許容荷重 (KN)注	質量 g	庫存
TBU-12025-S	25	6.0	6	M12×1.75	5.3	13	△
TBU-12035-S	35					19	△
TBU-12050-S	50					28	△
TBU-12025-F	25					13	△
TBU-12035-F	35					19	△
TBU-12050-F	50					28	△
TBU-12025-E	25					12	△
TBU-12035-E	35					18	△
TBU-12050-E	50					27	△
TBU-16025-S	25	8.5	8	M16×2	10.9	26	△
TBU-16035-S	35					39	△
TBU-16050-S	50					58	△
TBU-16025-F	25					26	△
TBU-16035-F	35					39	△
TBU-16050-F	50					58	△
TBU-16025-E	25					25	△
TBU-16035-E	35					38	△
TBU-16050-E	50					57	△

· 注)POM類型除外

Ex. 使用例

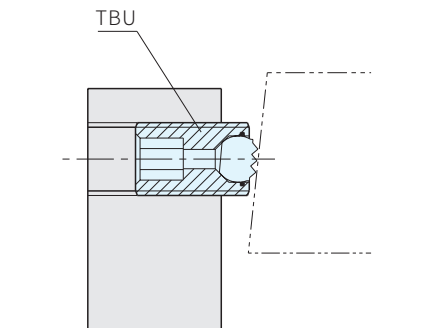

夾持及墊塊功能

訂貨： 交期：

TBU-12025-S