

RoHS SUS



齒面



平面



塑膠

名稱	材質	處理	硬度	顏色
本體	SCM440	染黑	-	-
珠子	SUS440	-	-	-
襯墊(齒面)	SKH51	染黑	HRC62	-
襯墊(平面)	SNCM220	染黑	HRC60	-
襯墊(塑膠)	POM	-	-	白

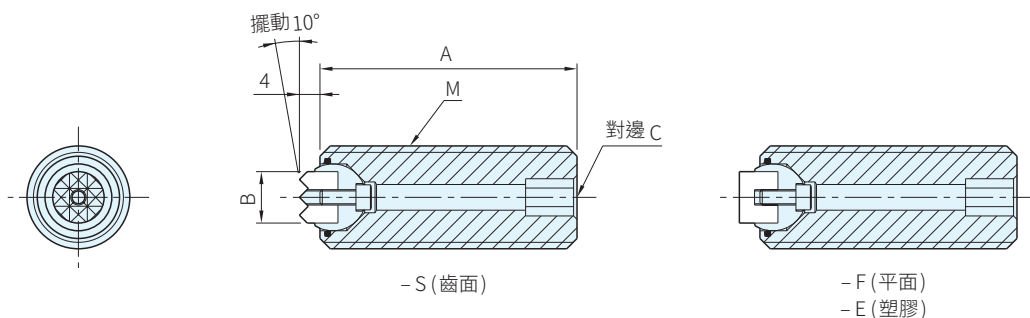

品號	A	B	C	M	許容荷重 (KN)注	質量 g	庫存
TBU-20030-S	30	10	10	M20×2.5	18.4	57	△
TBU-20050-S	50					90	△
TBU-20070-S	70					123	△
TBU-20030-F	30					57	△
TBU-20050-F	50					90	△
TBU-20070-F	70					123	△
TBU-20030-E	30					53	△
TBU-20050-E	50					86	△
TBU-20070-E	70					119	△
TBU-24040-S	40	12	10	M24×3	24.5	113	△
TBU-24080-S	80					210	△
TBU-24040-F	40					113	△
TBU-24080-F	80					210	△
TBU-24040-E	40					107	△
TBU-24080-E	80					204	△

· 注)POM類型除外

Ex. 使用例

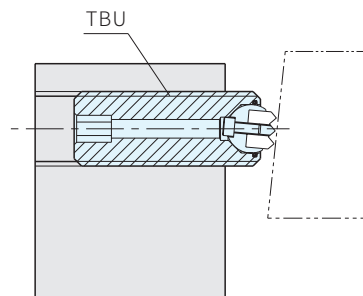

夾持及墊塊功能

Wa. 注意

襯墊可以從球型內側，以附屬的六角螺絲安裝及拆卸

訂貨： 交期：

TBU-20030-S