

RoHS

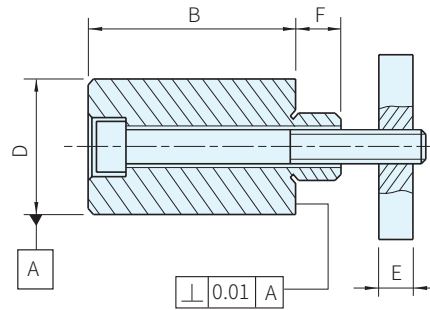

止動塊		固定板	
材質	處理	材質	處理
鋼	表面硬化	鋼	染黑

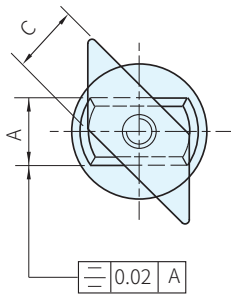

品號	A (h6) T槽尺寸	B		C -0.6	D ±0.01	E	F	螺絲 DIN 912	質量 (g)	庫存
		短型(±0.01)	長型(±0.2)							
23280.0110	10	15	-	10	20	6	8	M6×25	50	△
23280.0210		-	25					M6×35	75	
23280.0112	12	15	-	12	32	8	9	M6×25	55	
23280.0212		-	25					M6×35	81	
23280.0114	14	25	-	14	40	10	15	M8×35	200	
23280.0214		-	50					M8×60	355	
23280.0116	16	25	-	16	46	16	20	M8×45	220	
23280.0216		-	50					M8×70	375	
23280.0118	18	25	-	18	40	10	15	M10×50	360	
23280.0218		-	50					M10×75	600	
23280.0122	22	25	-	20	46	16	20	M10×55	410	
23280.0222		-	50					M10×80	650	
23280.0128	28	25	-	22	46	16	20	M12×60	630	
23280.0228		-	50					M12×90	950	

SP 特長

- 圓筒直線部份能快速精準的將工件定位，並可作為0-點參考值
- 短型止動塊高度公差研磨至±0.01mm，亦可作為高度定位之用

 訂貨： 交期： 天

23280.0110