

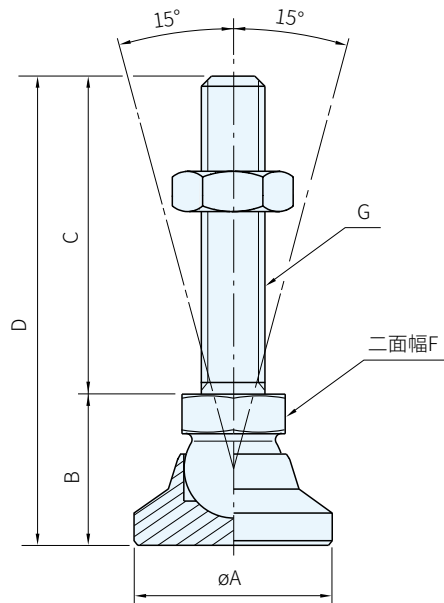

無止滑墊



腳座、螺牙	螺帽
材質	材質
SUS303	SUS304

品號	A	B	C	D	F	G	質量 (g)	容許荷重 (KN)	庫存
LM.SST-0010	25	19	40	59	12	M8×1.25	57	7	·
LM.SST-0020			63	82			67		·
LM.SST-0030	32	23	50	73	15	M10×1.5	113	11	·
LM.SST-0040			80	103			129		·
LM.SST-0050	40	26	63	89	17	M12×1.75	185	16	·
LM.SST-0060			100	126			211		·
LM.SST-0070	50	28	63	91	17	M12×1.75	258	16	·
LM.SST-0080			100	128			283		·
LM.SST-0090	60	36	80	116	24	M16×2	510	30	·
LM.SST-0100			125	161			561		·

Wa) 注意

- 帶螺帽
- 1KN=101.972kgf



螺帽	品號	庫存
	不銹鋼	
M8	SM14.1-8	·
M10	SM14.1-10	·
M12	SM14.1-12	·
M16	SM14.1-16	·

訂貨： 交期： 天

LM.SST-0010