

EN



SSP-12205



SSP-12210

材質	處理
鋼	鍍鋅

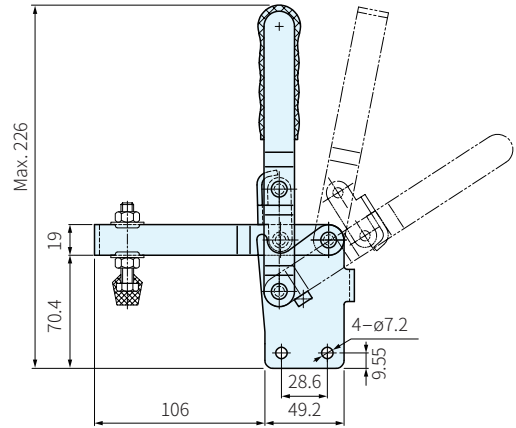
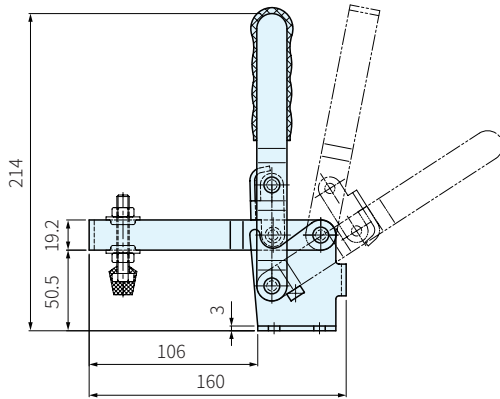
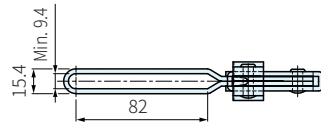
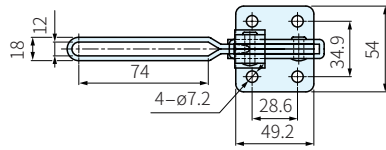

品號	夾持力 N	質量 g	把手移動	壓把移動	標準附件	備註	庫存
SSP-12205	1784	620	57°	101°	SSP-FC-109015-W	U型壓把、法蘭座	·
SSP-12210					SSP-FC-56212	U型壓把、直座	·

WA 注意

- 附件請參考本單元夾鉗附件
- 1N=0.101972kgf
- SSP-FC-109015-W不單獨販售

訂貨： 交期： 天

SSP-12205