

RoHS



CFN-010



CFN-020



CFN-030



CFN-040

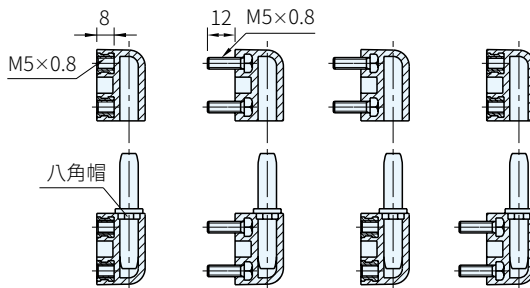
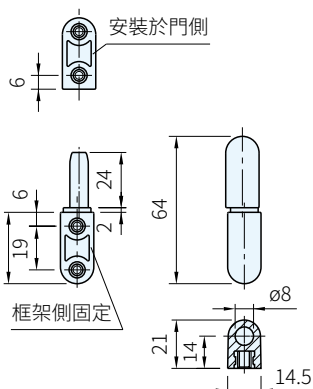

本體		銷子		母牙		公牙	
材質	顏色	材質	材質	處理	材質	處理	處理
PA+玻纖	霧黑	PA	黃銅	鍍銀	SUM22L	鍍銀	

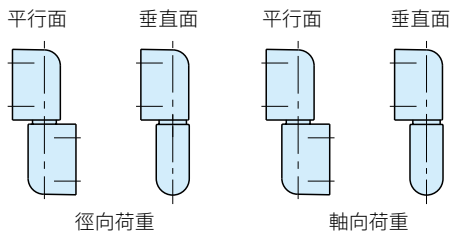

品號	最大鎖緊力矩 (Nm)	徑向荷重		軸向荷重		質量 (g)	庫存
		容許荷重Er[N]		容許荷重Ea[N]			
		平行面與垂直面		平行面與垂直面			
CFN-010	5	200		590		24	·
CFN-020						30	·
CFN-030						27	·
CFN-040							

Ex. 使用例

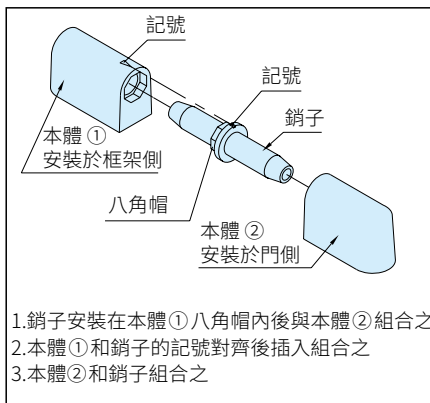
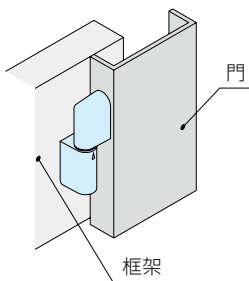

訂貨：品號 交期：1 天
CFN-010

■可拆卸的組合

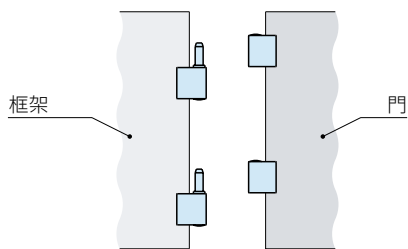

■不可拆卸的組合

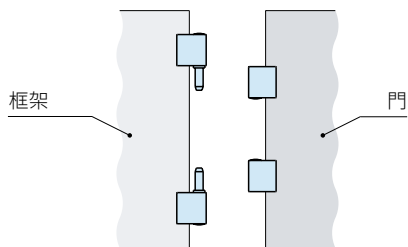

■門向上方傾斜時

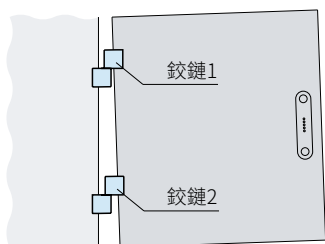

調整門和框架平行時，鉸鏈2的銷子以45°~180°間旋轉調整之

■門向下方傾斜時

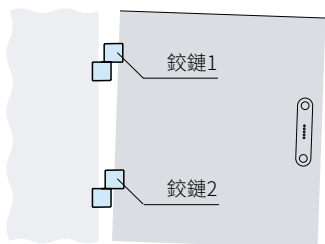

調整門和框架平行時，鉸鏈1的銷子以45°~180°間旋轉調整之

■調整方法

門和框架不平行時，轉動銷子即可調整角度

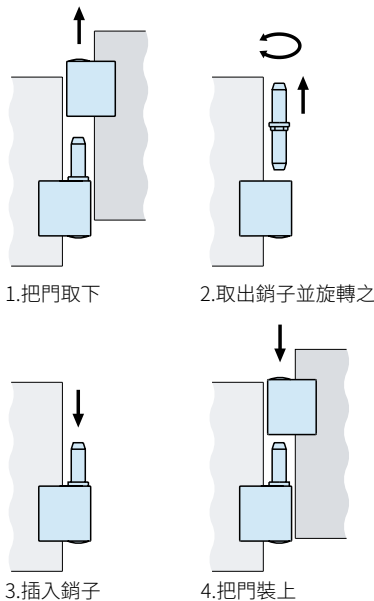

■門傾斜時的調整

銷子的調整角度是8階段×45° 調整門和框架平行時，只要調整上下鉸鏈其中一個的銷子即可

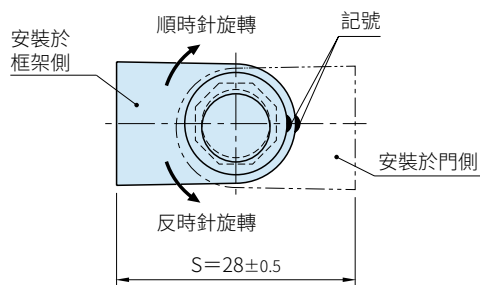

銷子反時針旋轉90°則 S 尺寸+0.5mm
銷子順時針旋轉90°則 S 尺寸-0.5mm