

RoHS



安裝螺絲	M(拉拔螺紋)
M 3	M 4
M 4	M 5
M 6	M 8
M 8	M10

材質	硬度
相當於SKD11	60~63HRC

① 拉拔螺絲高於安裝螺絲一個規格

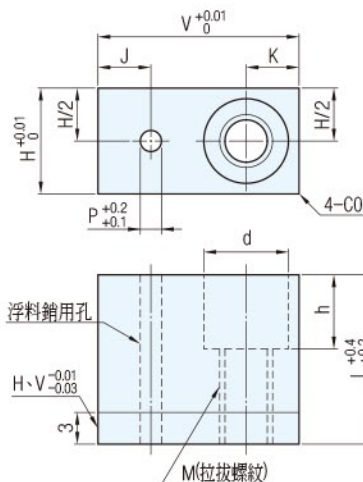

K	安裝螺絲			J	Catalog No.	V	H	L	P				
	d	h	規格										
4	6	7.5	M 3	3	TTNL	13	8	16	2				
				4		16							
				5		18							
				6.5		20							
5	8	8.5	M 4	4		18	10						
				5		20							
				6.5		22							
				8		25							
6.5	11	10.5	M 6	5		22	13			20	4		
				6.5		25							
				8		28							
				10		32							
				6.5		25						16	8
				8		28							
10	32												
12.5	38												
8	14	12.5	M 8	8	32	20	25	10					
				10	35								
				12.5	40								
				15	45								
				10	35				25	40			
				12.5	40								
15	45												
17.5	50												

**Wa. 注意**

• H8時不可指定P6・8・10, H10時不可指定P8・10

**Ex. 使用例**

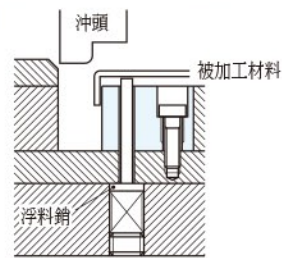

(拉拔螺絲使用範圍)

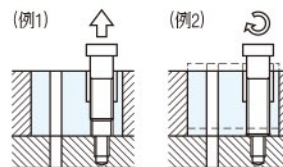

將螺絲擡入拉拔螺紋中，然後從下模固定板中拔出  
將螺絲擡入拉拔螺紋中，然後從下模浮起

(1) 浮料銷用孔的中心位置為通常(J, H/2)位置時

訂貨：Catalog No.   -  -  交期：15 天  
TTNL 25 13 - 25 - P2

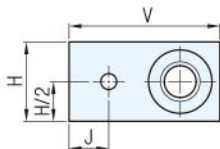

(2) 浮料銷用孔的位置為指定(X, Y)時

訂貨：Catalog No.   -  -  -  指定單位0.01mm 交期：15 天  
TTNL 25 13 - 25 - P2 - X4.60 - Y3.20

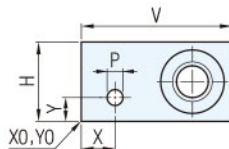

① 浮料孔有效範圍

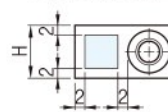

② X, Y指定單位0.01mm

追加加工

Alteration	Code	Spec.
	LC	變更全長 16 ≤ LC < 35 指定單位0.1mm(LKC併用時, 指定單位可為0.01mm)
	PKC	變更P尺寸公差 $P^{+0.2}_{+0.1} \rightarrow P^{+0.10}_{+0.05}$
	CC	V・H的4個角做C0.5倒角處理

Alteration	Code	Spec.
	LKC	變更全長公差 $L^{+0.4}_{+0.2} \rightarrow L^{+0.05}_0$
	VKC1	變更V・H公差 $V \cdot H^{+0.01}_0 \rightarrow V \cdot H^{+0.005}_0$
	VKC2	變更V・H公差 $V \cdot H^{+0.01}_0 \rightarrow V \cdot H^{-0.005}_0$
	NDC	無導入部 $V \cdot H^{0.01}_{0.05}$