

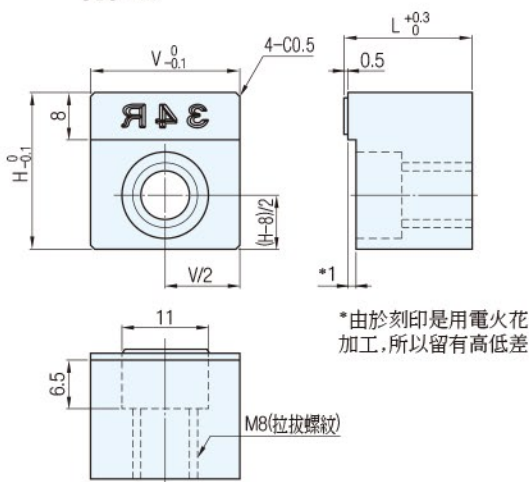

材質	硬度
相當於SKD11	60~63HRC

UES□M



TES□M

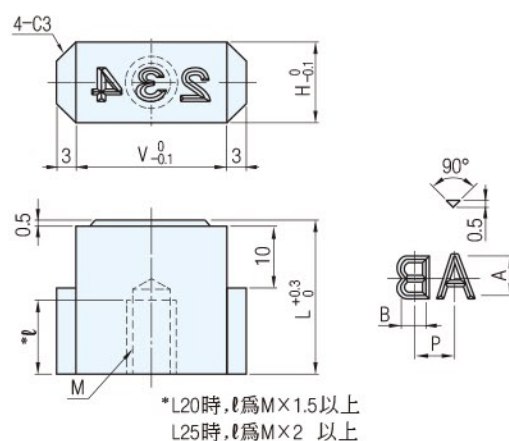

安裝螺栓 M	V	H	P	B	Catalog No.		A	L	字型(黑體) CHR
					TYPE	文字數			
6	16	22	3.5	2	UES	3M	3	20	0 1 2 3 4 5 6 7 8 9 A B C D E F G H I J K L M N O P Q R S T U V W X Y Z
	25					4M			
	32					5M			
	32					6M			
6	16	10	3.5	2	TES	3M	3	20	
	25					4M			
	32					5M			
	32					6M			
8	25	13	6.0	4	UES	3M	6	25	
	32					4M			
	32					5M			
	32					5M			

訂貨: Catalog No. - A - L - CHR 交期: 9 天 刻印的配置範例

UES3M - 3 - 25 - ABC
UES4M - 3 - 25 - ABCD

0 8 A
0 0 8 A

Ex. 使用例

(安裝時的使用範例) (拉拔螺紋使用範例)

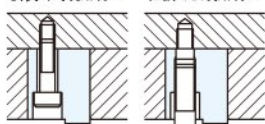

安裝方法1

安裝方法2

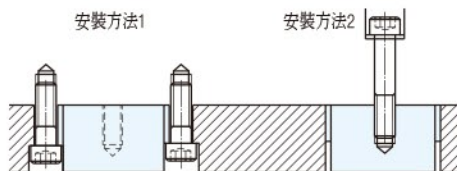

TES□M

- 1、安裝位置: 盡量選擇水平面, 將沖頭接觸部位垂直安裝
- 2、鎖固螺絲請高出安裝面0.25mm (沖裁件的沖入量為0.25mm)

UES□M

- 1、不必拆卸模具就可進行維護
- 2、利用墊片, 即使模具裝配之後也可進行微調

刻印方 型沖頭	字體
UES□M	0 1 2 3 4 5 6 7 8 9
TES□M	A B C D E F G H I J K L M N O P Q R S T
XEK□M	U V W X Y Z
XEN□M	