

ROSTFREI  
Inox  
Stainless  
Steel

**4 Type**

**E** With eyelet

**L** With mounting shackle

**Application examples**

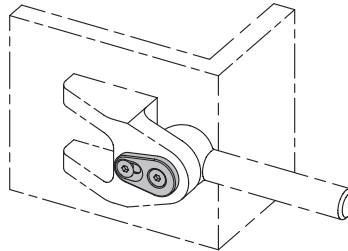
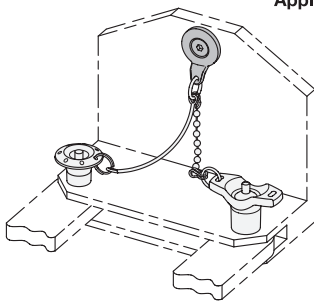

**2**

**3**

| d <sub>1</sub> | d <sub>2</sub> | d <sub>3</sub> | d <sub>4</sub> | d <sub>5</sub> | h | l <sub>1</sub> | l <sub>2</sub> | l <sub>3</sub> | l <sub>4</sub> | l <sub>5</sub> | s <sub>1</sub> | s <sub>2</sub> | Suitable key rings for type E |
|----------------|----------------|----------------|----------------|----------------|---|----------------|----------------|----------------|----------------|----------------|----------------|----------------|-------------------------------|
| 4,3            | 12             | 9,2            | 2,5            | 6              | 7 | 13,5           | 10,8           | 18             | 10             | 2              | 3              | 4              | Ø14                           |
| 4,3            | 15             | 9,2            | 2,5            | 6,3            | 7 | 15             | 12,3           | 21             | 11             | 4              | 3              | 4              | Ø14                           |
| 5,3            | 17             | 11,5           | 3              | 7,2            | 7 | 18,5           | 15             | 23             | 12             | 4              | 4              | 4,5            | Ø14 / Ø18                     |
| 5,3            | 22             | 11,5           | 3              | 7,5            | 9 | 21             | 17,5           | 28             | 15             | 6              | 4              | 4,5            | Ø14 / Ø18                     |
| 6,4            | 26             | 13,7           | 3,5            | 8,1            | 9 | 24             | 20,3           | 31             | 17             | 6              | 4              | 5              | Ø14 / Ø18 / Ø24               |

**Specification**

**1**

- Stainless steel
- Type E: metal injection molded AISI 316 LHC Tumbled
- Type L: sintered AISI 316 LHC Tumbled

• [Stainless Steel Characteristics](#) → Page 2166

• [RoHS](#)

**Accessory**

- Ball Chains GN 111 / GN 111.5 → [Page 1174](#)
- Retaining Cables GN 111.2 → [Page 1176](#)
- Spiral Retaining Cables GN 111.4 → [Page 1175](#)

**Information**

**NI**

Retaining washers GN 2344 are universally usable standard parts. Type E is suitable for use in connection with retaining cables and ball chains to mount other standard or securing parts in order to prevent loss. Type L is suitable, for example, for mounting bolts or axes, which can thereby simultaneously be secured in an axial and also in a radial position.

see also...

- [Assembly Pins GN 2342 \(Stainless Steel\)](#) → Page 1028

**How to order**

**GN 2344-NI-4,3-15-E**

- 1** Material
- 2** d<sub>1</sub>
- 3** d<sub>2</sub>
- 4** Type