

DIGITAL CENTERLINE AND EDGE TO CENTER CALIPERS

DATA
OUTPUT



1521-2002

- Non waterproof
- Measure hole center distance in the same or offset planes and edge to hole center distance
- Resolution: 0.01mm/0.0005"
- Buttons: on/off, set, mm/inch, preset (+, -)
- Automatic power off, move the digital unit to turn on power
- Battery CR2032
- Made of stainless steel

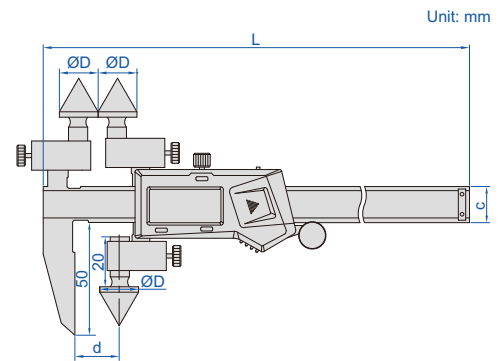

With data interface (data output cable code 7315-21, 7302-21, optional)

(mm)

Code	Range	Accuracy	ØD	d	L	c
1521-150	5-150mm/0.2-6"	±0.05mm	5	5	236	16
1521-1501	10-150mm/0.4-6"	±0.05mm	10	10	236	16
1521-1502	20-150mm/0.8-6"	±0.05mm	20	20	236	16
1521-200	5-200mm/0.2-8"	±0.05mm	5	5	285	16
1521-2001	10-200mm/0.4-8"	±0.05mm	10	10	285	16
1521-2002	20-200mm/0.8-8"	±0.05mm	20	20	285	16
1521-300	5-300mm/0.2-12"	±0.07mm	5	5	385	17
1521-3001	10-300mm/0.4-12"	±0.07mm	10	10	385	17
1521-3002	20-300mm/0.8-12"	±0.07mm	20	20	385	17

measure hole
center distance

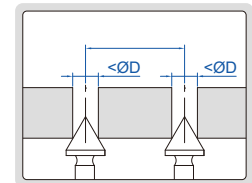

measure edge to
hole center distance

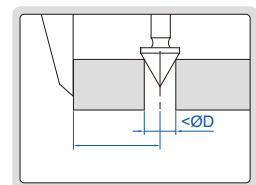

Built-in wireless (receiver code 7315-2/3/6/7/8/9 is required)

(mm)

Code	Range	Accuracy	ØD	d	L	c
1521-150WL	5-150mm/0.2-6"	±0.05mm	5	5	236	16
1521-1501WL	10-150mm/0.4-6"	±0.05mm	10	10	236	16
1521-1502WL	20-150mm/0.8-6"	±0.05mm	20	20	236	16
1521-200WL	5-200mm/0.2-8"	±0.05mm	5	5	285	16
1521-2001WL	10-200mm/0.4-8"	±0.05mm	10	10	285	16
1521-2002WL	20-200mm/0.8-8"	±0.05mm	20	20	285	16
1521-300WL	5-300mm/0.2-12"	±0.07mm	5	5	385	17
1521-3001WL	10-300mm/0.4-12"	±0.07mm	10	10	385	17
1521-3002WL	20-300mm/0.8-12"	±0.07mm	20	20	385	17