

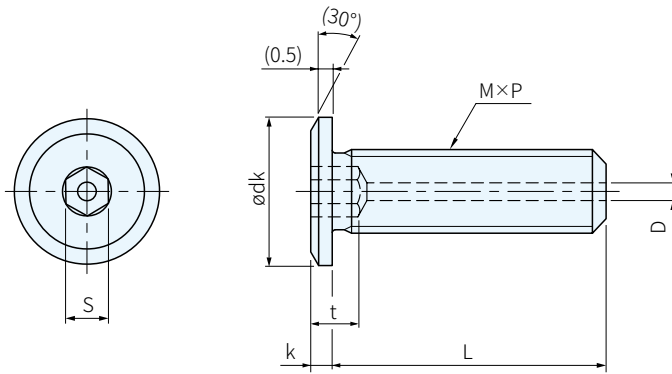

材質		代號			
SUS		SS			
M×P	頭部外徑 ødk	頭部高度 k	六角孔兩面寬 S	六角孔深t min	孔徑 øD
4×0.7	8	1.5	2	1.7	1.5
5×0.8	9		3	1.8	
8×1.25	13		4	4.2	



Type	品號	M×P	庫存
ULHAR	M - L		
	4 - 6	4×0.7	·
	5 - 8	5×0.8	·
	8 - 12	8×1.25	·
8 - 16	·		

訂貨： - 交期： 天
 ULHAR 4-6 - SS