

- 1
- 2
- 3
- 4
- 5
- 6
- 7
- 8
- 9
- 10
- 11
- 12**
- 13
- 14
- 15
- 16
- 17
- 18

BASE

Glass-fibre reinforced polyamide based (PA) technopolymer, black colour, matte finish.

ARTICULATED STEM

Glass-fibre reinforced polyamide based (PA) SUPER-technopolymer, with hexagonal socket and regulation hexagon.

STANDARD EXECUTIONS

- **LV.FO+STP**: without no-slip disk.
- **LV.FO-AS+STP**: with NBR rubber no-slip disk, hardness 70 Shore A, supplied assembled to the base.

FEATURES

Thanks to the property of the SUPER-technopolymer stem, high rigidity and mechanical resistance are obtained in addition to natural resistance to corrosion.

The special knurling under the lower lip of the base provides excellent stability and grip when using the levelling element without no-slip disk even on surfaces that are not perfectly flat.

The particular assembling system of the no-slip disk to the base assures a perfect anchoring, preventing separation even in case of impact during transport or of adhesion (sticking) to the floor (see No-slip disks on page).

ORDER INFORMATION

The levelling feet are supplied unassembled to make carriage and storage easier. The components (base and stem) are supplied in separate packing: less volume taken and better protection from scratches and dirt.

To order bases and stems separately, see:

- table of possible combinations Bases/Stems (see page 839)
- the codes of the Bases (see page 836)
- the codes of the Stems (see page 840).

ACCESSORIES ON REQUEST

NT. (see page -): AISI 304 stainless steel or zinc-plated steel nut.



ELESA Original design

Break the diaphragm

Make a hole

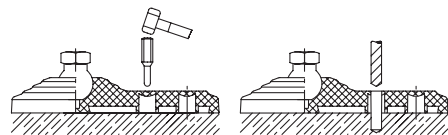
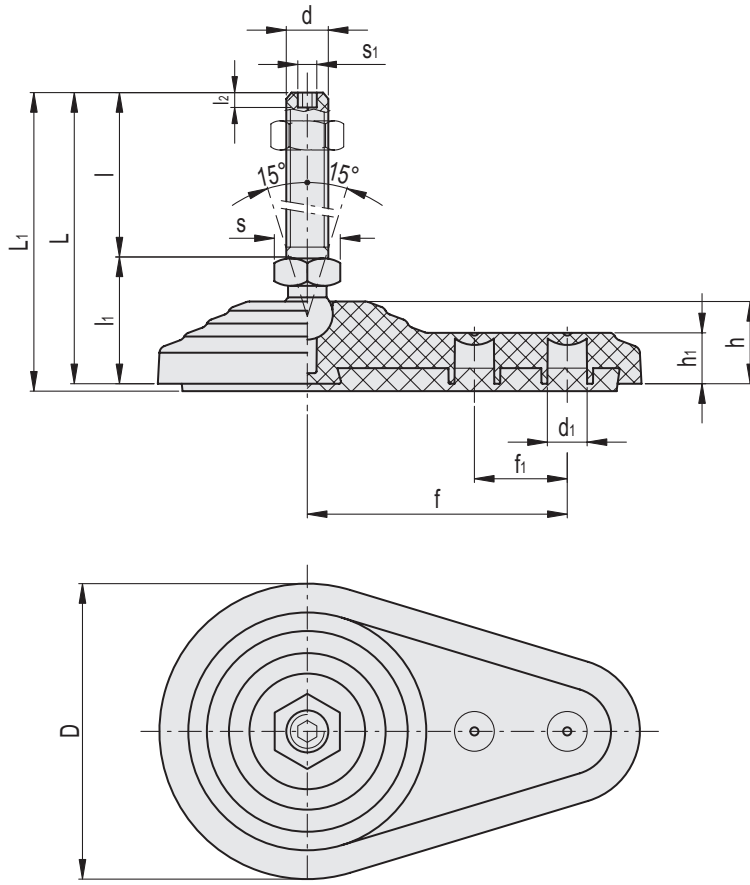

Fig.1

- 1
- 2
- 3
- 4
- 5
- 6
- 7
- 8
- 9
- 10
- 11
- 12
- 13
- 14
- 15
- 16
- 17
- 18



LV.FO-AS-STP

Code	Description	D	d	d1	L	L1	l	l1	l2	s	s1	Articulation ∅	Max. limit static load [N]	⚖
516013	LV.FO-60-14-AS-STP-M8x44	60	M8	8.5	75.5	78.5	44	31.5	5	14	3	14	2700	72
516018	LV.FO-60-14-AS-STP-M8x69	60	M8	8.5	100.5	103.5	69	31.5	5	14	3	14	2700	73.5
516023	LV.FO-60-14-AS-STP-M10x44	60	M10	8.5	75.5	78.5	44	31.5	6	14	4	14	4800	73.5
516028	LV.FO-60-14-AS-STP-M10x69	60	M10	8.5	100.5	103.5	69	31.5	6	14	4	14	5000	76
516033	LV.FO-60-14-AS-STP-M10x99	60	M10	8.5	130.5	133.5	99	31.5	6	14	4	14	5100	79
516038	LV.FO-60-14-AS-STP-M12x44	60	M12	8.5	75.5	78.5	44	31.5	7	14	5	14	6800	75
516043	LV.FO-60-14-AS-STP-M12x69	60	M12	8.5	100.5	103.5	69	31.5	7	14	5	14	7000	79
516048	LV.FO-60-14-AS-STP-M12x99	60	M12	8.5	130.5	133.5	99	31.5	7	14	5	14	7000	83.5
516123	LV.FO-80-14-AS-STP-M8x44	80	M8	10.5	77	80	44	33	5	14	3	14	2700	124
516127	LV.FO-80-14-AS-STP-M8x69	80	M8	10.5	102	105	69	33	5	14	3	14	2700	125.5
516223	LV.FO-80-14-AS-STP-M10x44	80	M10	10.5	77	80	44	33	6	14	4	14	4800	125.5
516227	LV.FO-80-14-AS-STP-M10x69	80	M10	10.5	102	105	69	33	6	14	4	14	5000	128
516233	LV.FO-80-14-AS-STP-M10x99	80	M10	10.5	132	135	99	33	6	14	4	14	5100	131
516323	LV.FO-80-14-AS-STP-M12x44	80	M12	10.5	77	80	44	33	7	14	5	14	6800	127
516327	LV.FO-80-14-AS-STP-M12x69	80	M12	10.5	102	105	69	33	7	14	5	14	7000	131
516333	LV.FO-80-14-AS-STP-M12x99	80	M12	10.5	132	135	99	33	7	14	5	14	7000	135.5

* The max static load is the value above which the load applied to the element may cause some plastic material breakage, in particular conditions of use. Obviously, a factor that takes into consideration the importance and the safety level of the specific application must be applied to this value.

Levelling feet and supports