

1 BASE

Glass-fibre reinforced polyamide based (PA) technopolymer, black colour, matte finish.

2 ARTICULATED STEM

Glass-fibre reinforced polyamide based (PA) SUPER-technopolymer, with hexagonal socket and regulation hexagon.

STANDARD EXECUTIONS

- **LS.A-STP**: without no-slip disk.
- **LS.A-AS-STP**: with NBR rubber no-slip disk, hardness 70 Shore A, supplied assembled to the base.

FEATURES

Thanks to the property of the SUPER-technopolymer stem, high rigidity and mechanical resistance are obtained in addition to natural resistance to corrosion.

The particular assembling system of the no-slip disk to the base assures a perfect anchoring, preventing separation even in case of impact during transport or of adhesion (sticking) to the floor (see No-slip disks on page).

ORDER INFORMATION

The levelling feet are supplied unassembled to make carriage and storage easier. The components (base and stem) are supplied in separate packing: less volume taken and better protection from scratches and dirt.

To order bases and stems separately, see:

- table of possible combinations Bases/Stems (see page 839)
- the codes of the Bases (see page 836)
- the codes of the Stems (see page ...).

ACCESSORIES ON REQUEST

NT. (see page -): AISI 304 stainless steel or zinc-plated steel nut.



ELESA Original design

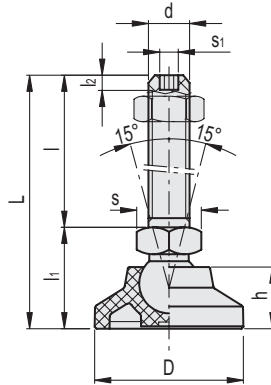

LS.A-STP

Code	Description	D	d	L	l	l1	l2	h	s	s1	Articulation Ø	Max. limit static load* [N]	⚖️
341123	LS.A-25-14-STP-M8x44	25	M8	69	44	24	5	17	14	3	14	2700	12
341127	LS.A-25-14-STP-M8x69	25	M8	94	69	24	5	17	14	3	14	2700	13.5
341223	LS.A-25-14-STP-M10x44	25	M10	69	44	24	6	17	14	4	14	4800	13.5
341227	LS.A-25-14-STP-M10x69	25	M10	94	69	24	6	17	14	4	14	5000	16
341233	LS.A-25-14-STP-M10x99	25	M10	124	99	24	6	17	14	4	14	5100	19
341323	LS.A-25-14-STP-M12x44	25	M12	69	44	24	7	17	14	5	14	6800	15
341327	LS.A-25-14-STP-M12x69	25	M12	94	69	24	7	17	14	5	14	7000	19
341333	LS.A-25-14-STP-M12x99	25	M12	124	99	24	7	17	14	5	14	7000	23.5
342123	LS.A-32-14-STP-M8x44	32	M8	70	44	25	5	17	14	3	14	2700	16
342127	LS.A-32-14-STP-M8x69	32	M8	95	69	25	5	17	14	3	14	2700	17.5
342223	LS.A-32-14-STP-M10x44	32	M10	70	44	25	6	17	14	4	14	4800	17.5
342227	LS.A-32-14-STP-M10x69	32	M10	95	69	25	6	17	14	4	14	5000	20
342233	LS.A-32-14-STP-M10x99	32	M10	125	99	25	6	17	14	4	14	5100	23
342323	LS.A-32-14-STP-M12x44	32	M12	70	44	25	7	17	14	5	14	6800	19
342327	LS.A-32-14-STP-M12x69	32	M12	95	69	25	7	17	14	5	14	7000	23
342333	LS.A-32-14-STP-M12x99	32	M12	125	99	25	7	17	14	5	14	7000	27.5
343123	LS.A-40-14-STP-M8x44	40	M8	69.5	44	25	5	17	14	3	14	2700	21
343127	LS.A-40-14-STP-M8x69	40	M8	94.5	69	25	5	17	14	3	14	2700	22.5
343223	LS.A-40-14-STP-M10x44	40	M10	69.5	44	25	6	17	14	4	14	4800	22.5
343227	LS.A-40-14-STP-M10x69	40	M10	94.5	69	25	6	17	14	4	14	5000	25
343233	LS.A-40-14-STP-M10x99	40	M10	124.5	99	25	6	17	14	4	14	5100	28
343323	LS.A-40-14-STP-M12x44	40	M12	69.5	44	25	7	17	14	5	14	6800	24
343327	LS.A-40-14-STP-M12x69	40	M12	94.5	69	25	7	17	14	5	14	7000	28
343333	LS.A-40-14-STP-M12x99	40	M12	124.5	99	25	7	17	14	5	14	7000	32.5
344123	LS.A-50-14-STP-M8x44	50	M8	72	44	27	5	19	14	3	14	2700	27
344127	LS.A-50-14-STP-M8x69	50	M8	97	69	27	5	19	14	3	14	2700	28.5
344223	LS.A-50-14-STP-M10x44	50	M10	72	44	27	6	19	14	4	14	4800	28.5
344227	LS.A-50-14-STP-M10x69	50	M10	97	69	27	6	19	14	4	14	5000	31
344233	LS.A-50-14-STP-M10x99	50	M10	127	99	27	6	19	14	4	14	5100	34
344323	LS.A-50-14-STP-M12x44	50	M12	72	44	27	7	19	14	5	14	6800	30
344327	LS.A-50-14-STP-M12x69	50	M12	97	69	27	7	19	14	5	14	7000	34
344333	LS.A-50-14-STP-M12x99	50	M12	127	99	27	7	19	14	5	14	7000	38.5
344613	LS.A-60-14-STP-M8x44	60	M8	79	44	33	5	24	14	3	14	2700	41
344617	LS.A-60-14-STP-M8x69	60	M8	104	69	33	5	24	14	3	14	2700	42.5
344623	LS.A-60-14-STP-M10x44	60	M10	79	44	33	6	24	14	4	14	4800	42.5
344627	LS.A-60-14-STP-M10x69	60	M10	104	69	33	6	24	14	4	14	5000	45
344633	LS.A-60-14-STP-M10x99	60	M10	134	99	33	6	24	14	4	14	5100	48
344723	LS.A-60-14-STP-M12x44	60	M12	79	44	33	7	24	14	5	14	6800	44
344727	LS.A-60-14-STP-M12x69	60	M12	104	69	33	7	24	14	5	14	7000	48
344733	LS.A-60-14-STP-M12x99	60	M12	134	99	33	7	24	14	5	14	7000	52.5

* The max static load is the value above which the load applied to the element may cause some plastic material breakage, in particular conditions of use. Obviously, a factor that takes into consideration the importance and the safety level of the specific application must be applied to this value.



- 1
- 2
- 3
- 4
- 5
- 6
- 7
- 8
- 9
- 10
- 11
- 12
- 13
- 14
- 15
- 16
- 17
- 18

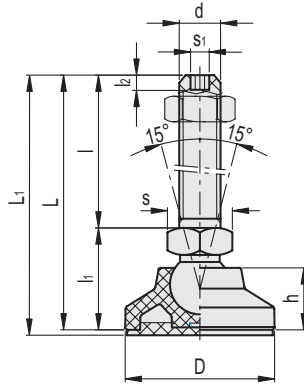

LS.A-AS-STP

Code	Description	D	d	L	L1	l	l1	l2	h	s	s1	Articulation ∅	Max. limit static load* [N]	
346123	LS.A-25-14-AS-STP-M8x44	25	M8	69	72	44	25	5	17	14	3	14	2700	14
346127	LS.A-25-14-AS-STP-M8x69	25	M8	94	97	69	25	5	17	14	3	14	2700	15.5
346223	LS.A-25-14-AS-STP-M10x44	25	M10	69	72	44	25	6	17	14	4	14	4800	15.5
346227	LS.A-25-14-AS-STP-M10x69	25	M10	94	97	69	25	6	17	14	4	14	5000	18
346233	LS.A-25-14-AS-STP-M10x99	25	M10	124	127	99	25	6	17	14	4	14	5100	21
346323	LS.A-25-14-AS-STP-M12x44	25	M12	69	72	44	25	7	17	14	5	14	6800	17
346327	LS.A-25-14-AS-STP-M12x69	25	M12	94	97	69	25	7	17	14	5	14	7000	21
346333	LS.A-25-14-AS-STP-M12x99	25	M12	124	127	99	25	7	17	14	5	14	7000	25.5
347123	LS.A-32-14-AS-STP-M8x44	32	M8	70	73	44	26	5	17	14	3	14	2700	20
347127	LS.A-32-14-AS-STP-M8x69	32	M8	95	98	69	26	5	17	14	3	14	2700	21.5
347223	LS.A-32-14-AS-STP-M10x44	32	M10	70	73	44	26	6	17	14	4	14	4800	21.5
347227	LS.A-32-14-AS-STP-M10x69	32	M10	95	98	69	26	6	17	14	4	14	5000	24
347233	LS.A-32-14-AS-STP-M10x99	32	M10	125	128	99	26	6	17	14	4	14	5100	27
347323	LS.A-32-14-AS-STP-M12x44	32	M12	70	73	44	26	7	17	14	5	14	6800	23
347327	LS.A-32-14-AS-STP-M12x69	32	M12	95	98	69	26	7	17	14	5	14	7000	27
347333	LS.A-32-14-AS-STP-M12x99	32	M12	125	128	99	26	7	17	14	5	14	7000	31.5
348123	LS.A-40-14-AS-STP-M8x44	40	M8	69.5	72.5	44	25.5	5	17	14	3	14	2700	28
348127	LS.A-40-14-AS-STP-M8x69	40	M8	94.5	97.5	69	25.5	5	17	14	3	14	2700	29.5
348223	LS.A-40-14-AS-STP-M10x44	40	M10	69.5	72.5	44	25.5	6	17	14	4	14	4800	29.5
348227	LS.A-40-14-AS-STP-M10x69	40	M10	94.5	97.5	69	25.5	6	17	14	4	14	5000	32
348233	LS.A-40-14-AS-STP-M10x99	40	M10	124.5	127.5	99	25.5	6	17	14	4	14	5100	35
348323	LS.A-40-14-AS-STP-M12x44	40	M12	69.5	72.5	44	25.5	7	17	14	5	14	6800	31
348327	LS.A-40-14-AS-STP-M12x69	40	M12	94.5	97.5	69	25.5	7	17	14	5	14	7000	35
348333	LS.A-40-14-AS-STP-M12x99	40	M12	124.5	127.5	99	25.5	7	17	14	5	14	7000	39.5
349123	LS.A-50-14-AS-STP-M8x44	50	M8	72	75	44	28	5	19	14	3	14	2700	39
349127	LS.A-50-14-AS-STP-M8x69	50	M8	97	100	69	28	5	19	14	3	14	2700	40.5
349223	LS.A-50-14-AS-STP-M10x44	50	M10	72	75	44	28	6	19	14	4	14	4800	40.5
349227	LS.A-50-14-AS-STP-M10x69	50	M10	97	100	69	28	6	19	14	4	14	5000	43
349233	LS.A-50-14-AS-STP-M10x99	50	M10	127	130	99	28	6	19	14	4	14	5100	46
349323	LS.A-50-14-AS-STP-M12x44	50	M12	72	75	44	28	7	19	14	5	14	6800	42
349327	LS.A-50-14-AS-STP-M12x69	50	M12	97	100	69	28	7	19	14	5	14	7000	46
349333	LS.A-50-14-AS-STP-M12x99	50	M12	127	130	99	28	7	19	14	5	14	7000	50.5
349613	LS.A-60-14-AS-STP-M8x44	60	M8	79	82	44	35	5	24	14	3	14	2700	58
349617	LS.A-60-14-AS-STP-M8x69	60	M8	104	107	69	35	5	24	14	3	14	2700	59.5
349623	LS.A-60-14-AS-STP-M10x44	60	M10	79	82	44	35	6	24	14	4	14	4800	59.5
349627	LS.A-60-14-AS-STP-M10x69	60	M10	104	107	69	35	6	24	14	4	14	5000	62
349633	LS.A-60-14-AS-STP-M10x99	60	M10	134	137	99	35	6	24	14	4	14	5100	65
349723	LS.A-60-14-AS-STP-M12x44	60	M12	79	82	44	35	7	24	14	5	14	6800	61
349727	LS.A-60-14-AS-STP-M12x69	60	M12	104	107	69	35	7	24	14	5	14	7000	65
349733	LS.A-60-14-AS-STP-M12x99	60	M12	134	137	99	35	7	24	14	5	14	7000	69.5

Levelling feet and supports

* The max static load is the value above which the load applied to the element may cause some plastic material breakage, in particular conditions of use. Obviously, a factor that takes into consideration the importance and the safety level of the specific application must be applied to this value.