

RoHS

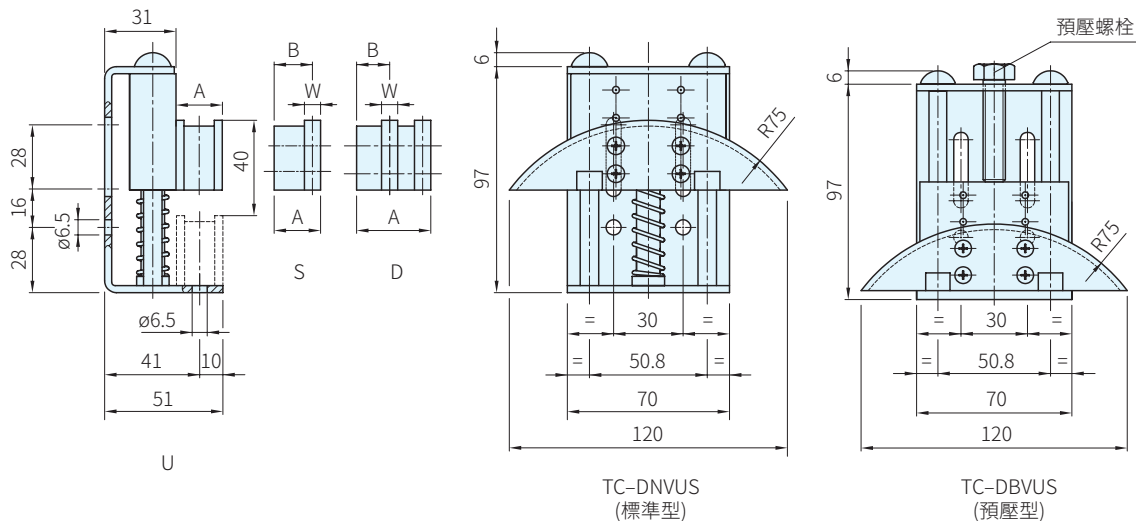

托架		鏈條導版
材質	處理	材質
鋼	烤漆	PE



標準型			預壓型			鏈條 DIN 8187		A	B	W	荷重 (N)		質量 (kg)	
品號	庫存	Code	品號	庫存	Code	鏈條					初壓	終壓		
						ISO NO.	ANSI NO.							
TC-DN10VUS	△	BL011180	TC-DB10VUS	△	BL011220	≤06B	-	20	-	-	36	79	0.46	
TC-DN20VUS	△	BL011181	TC-DB20VUS	△	BL011221						64	142		
TC-DN10V2S	△	BL011184	TC-DB10V2S	△	BL011224	08B	40				17.0	7		36
TC-DN20V2S	△	BL011185	TC-DB20V2S	△	BL011225				64	142				
TC-DN10V3S	△	BL011186	TC-DB10V3S	△	BL011226	10B	50		15.5	11	36	79		0.48
TC-DN20V3S	△	BL011187	TC-DB20V3S	△	BL011227	12B	60				64	142		
TC-DN10V4S	△	BL011188	TC-DB10V4S	△	BL011228	06B	-	32	11.5	5	36	79		
TC-DN20V4S	△	BL011189	TC-DB20V4S	△	BL011229						64	142		
TC-DN10V1D	△	BL011194	TC-DB10V1D	△	BL011234						08B	40	15.2	7
TC-DN20V1D	△	BL011195	TC-DB20V1D	△	BL011235				64	142				
TC-DN10V2D	△	BL011196	TC-DB10V2D	△	BL011236				10B	50	11.3	9	36	79
TC-DN20V2D	△	BL011197	TC-DB20V2D	△	BL011237								64	142
TC-DN10V3D	△	BL011198	TC-DB10V3D	△	BL011238					36	79			
TC-DN20V3D	△	BL011199	TC-DB20V3D	△	BL011239					64	142			

備註

- 工作速度 ≤ 60 m/min
- 工作溫度 ≤ 70°C

訂貨： 品號 交期： 20 天

TC-DN10VUS