

Pro'sKit®

MT-2207

Protective Multifunction Analog Multimeter



User's Manual

1st Edition, 2023

©2023 Copyright by Prokit's Industries Co., Ltd.

INTRODUCTION

This Multi-meter is an accurate, safe handheld meter that comes with mirrored Aluminum dial, robust protective holster alongside, built-in stand and hook-up design. MT-2027 is powered by batteries, offers accurate, reliable measurement of DC/AC Voltage, +/-DCV, DC Current, Resistance and Diode, LED, Transistor, Decibels, Continuity test and Capacitance with very high sensitivity quality movement.

This meter is designed with double-sided glass-epoxy PCB, full overload & misused protection via two Fuses, voltage Suppressor & Diodes, and smart protection on Ω testing via the extra Resettable Fuse & Varistor. Ideal for indoor use in laboratory, school, workshop, and home applications.

SPECIFICATION

Safety Category: IEC61010-1, CAT II 1000V CAT III 500V and Pollution Degree 2.

Common Environment: 23°C±5°C, less than 75% RH.

Operating temperature: 0°C to 40°C, 32 °F to 104 °F

Storage temperature: -10 °C to 50°C, 14 °F to 122°F

Operating Humidity Scope: Less than 90% RH.

Storage Humidity Scope: less than 80% RH.

Dimensione: 179(L) x 118(W) x 50(H) mm

Weight: 400g approx. (not including test leads and batteries)

Accessories: One pair of test leads;

Spare Fuse: F0.5A 250V;F10A 250V, Φ 5x20mm

Test Functions	Range	Accuracy	Remarks
DC V	0-0.25-1-2.5-10-50-250-500-1000V(2500V)	± 3% FSD. ± 4% FSD for 1000V(2500V)	Input Impedance: 20K Ω /V, UP 50V 9K Ω /V; Overload Protection: 0.25V/1V/2.5V/10V/50 V Range, 250V Max. 250V/500V/1000V Range, 1000V AC/DC Max. 2500V Range, 2500V AC/DC Max.
AC V	0-10-50-250V-500V -1000V(2500V)	± 4% FSD. ± 5% FSD for 1000V(2500V)	Input Impedance: 9K Ω /V Overload Protection: 10V/50VRange, 250V Max. Band width: 40

			~10K Hz 1000V Range ,1000V AC/DC Max. 2500V Range ,2500V AC/DC Max.
DC mA	0-50uA-0.5mA- 5mA-50mA- 500mA(10A)	± 3% FSD. ± 4% FSD for 10A	Drop Voltage: 250 mV Overload protected by Fuses 0.5A/250V & 10A / 250V at 10A range, Max. test time 10sec. for 10A.
Ω	X 1: 0.2 ~ 2KΩ Midscale at 20Ω X 10: 2 ~ 20KΩ Midscale at 200Ω X 100: 20 ~ 200KΩ Midscale at 2000Ω X1K: 200~ 2MΩ Midscale at 0KΩ X10K: 2K ~ 20MΩ Midscale at 200KΩ	± 4% of ARC of Scale Length	Overload protected by the voltage Suppressor & Fuse (3sec.)
Capacitance (uF)	Cx1: 50uF Cx10: 500uF Cx100: 5000uF Cx1K & Cx10K: Approx. Value	Approx. Value	Overload protected by the voltage Suppressor & Fuse (3sec.)
BATT Check	0 -1.2V- 1.5V- 2.0V-3V-3.6V: BAD (red)- ? – GOOD(green)	± 5% of ARC of Scale Length	Overload protected by the voltage Suppressor & Fuse (3sec.)
Transistor Check	hFE: 0-1000 via special hFE socket	Approx. Value	At Ω X 10 Range
LED, Diode Check	via special hFE socket	Approx. Value	At Ω X 10 Range
Decibel	-22 dB ~ + 62 dB	Approx. Value	At ACV ranges

	(0dB=1mW at 600Ω)		Via Test Leads
Continuity Check	Beeper sounding under 50 Ohm		Overload protected by the voltage Suppressor & Fuse (3sec.)
Power Source	Internal Battery: AAA, 1.5V 2pcs,		

Name of part

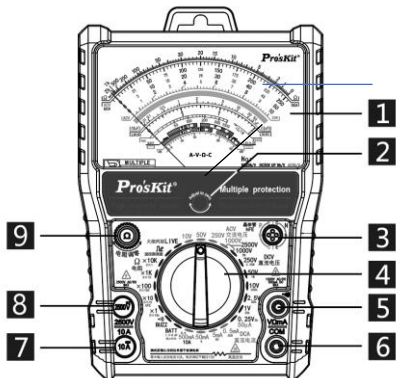

1. Scale panel 2. Point zero adjust 3. hFE socket 4. Range switch
 5. V Ω mA input socket 6. COM input socket 7. 10A input socket
 8. 2500V input socket 9. Resistance zero adjust

CALIBRATION

Ohms Zero Adjustor located at the right side of the panel. Adjust the meter pointer to the Zero mark on the right side of Ohm scale of the meter dial when the test leads are touched together.

Mechanical Adjustor Screw: located right side below the center of the meter dial to set pointer to Zero mark at the left side of the scale.

(-) Jack: Plug-in connector at the lower left on the panel for black, negative test lead.

(+) Jack: Plug-in connector at the lower right on the panel for Red, positive test lead.

STAND & HOOK-UP

This meter can be used in any operating position. It has an oblique bracket and a hook behind it. Users should choose according to their own needs. And it has magnets on its back to absorb the suspension.

OPERATING INSTRUCTIONS



CAUTION!

When making voltage or current measurements, develop the habit of turning off all power to the circuit under test. Connect the test leads at the desired points in the circuit, and then turn on the power while taking readings. Turn off the power before disconnecting the test leads from the circuit.

INTERNAL BATTERY CHECK

To check the battery condition, insert the black test lead into the (-) jack. Set the range switch to the R X1 range position and short the ends of the two sides of the test leads. If the pointer can not be brought to the zero mark, replace the 1.5V batteries. (See battery replacement.)

BEFORE OPERATING

1. Set the range switch to the proper position before making any measurement.
2. Never apply more voltage or current than the rated value in every position.
3. When the voltage or current to be measured is not known, always start with the highest range.
4. If meter indication is in the lower half of the scale and falls within the range of a lower scale, reset selector switch to the lower range for greatest accuracy.
5. If the meter won't work at all, check the fuse located on the PCB. If it's blown, replace it. (See fuse replacement.)
6. Avoid placing the meter where extreme shock or continuous vibration is encountered and do not store in excessively hot or damp places. Although very rugged, the meter is a sensitive measuring device and should be handled carefully & properly.
7. Do not check resistance, transistor, diode, LED, or capacitance when live voltage or current input across the circuit.
8. When the meter is not in use, keep the selector switch to the "DC or AC voltage" range position, this provides direct short across meter movement for minimum needle bounce when transporting meter.
9. If you should accidentally apply excessive voltage or current on a certain range, disconnect the leads from the circuit as quickly as possible, check instrument operation on that range by applying proper input. If the meter does not operate properly, check fuse. If it is blown replace it. (See fuse replacement.)

OPERATION PROCEDURES

DC Voltage Measurement



WARNING: USE EXTREME CARE WHEN MAKING MEASUREMENTS FOR HIGH VOLTAGE. DO NOT TOUCH TERMINAL OR PROBE ENDS.

1. Set the selector switch to the appropriate DCV range to be used.
2. Connect the BLACK test lead to the “-COM” jack and the RED test lead to the “+” jack.
3. If measuring a voltage above 1000V, insert the red test lead into the “2500v” jack.
4. If you know the polarity of the circuit to be tested, connect the black probe to the negative side.
5. If you don't know the polarity, connect the probes to opposite sides of the circuit and watch the pointer. If it goes to the left, reverse the probes. The RED probe will be connected to the positive.
6. Check the needle position and get the reading on V.A scale.

AC Voltage Measurement



WARNING: USE EXTREME CARE WHEN MAKING MEASUREMENTS FOR HIGH VOLTAGE. DO NOT TOUCH TERMINAL OR PROBE ENDS!

1. Set the selector switch to the appropriate ACV range to be used and connect the test leads across the circuit or load under measurement. (Polarity of the test probes is unimportant on ACV test.)
2. Connect the BLACK test lead to the “-COM” jack and the RED test lead to the “+” jack.
3. If measuring a voltage above 1000V, insert the red test lead into the “2500v” jack.
4. Check the needle position and get the reading on V.A scale.

Note: Measuring high voltage at 2500V range, should be wear rubber insulated gloves on both hands and be in a dry insulated environment.

DC Current Measurement



WARNING: DO NOT APPLY VOLTAGE TO MEASURING TERMINAL WHILE RANGE SWITCH IS IN CURRENT POSITION. DO NOT ATTEMPT TO MEASURE AC CURRENT.

1. Set the selector switch to the appropriate DC mA range to be used and connect the test leads in series with the circuit or the load under measurement. If the pointer deflects to the left, reverse the probes.

2. Connect the BLACK test lead to the "-COM" jack and the RED test lead to the Red "+" jack for Current at/less than 0.5A. For large current max. 10A, move the red test lead to the Red "10A" jack.
3. Check the needle position and get the reading on V.A scale.

NOTE: Excessive current input across mA range will blow the fuse that must be replaced by a same fuse rating 0.5A/250V or 10A/250V. The maximum testing time once must be not more than 10sec. and pause 5min. for next time at big current load.

The maximum terminal voltage drop is 250mV except for the 10A range.

NOTE: If connected incorrectly with the voltage at these ranges, quickly remove the test leads from the circuit as to avoid damage to this tester. (This tester can afford the voltage <250V DC/AC rms. for the period of 5 seconds max.)

Resistance Measurement



WARNING: DO NOT APPLY VOLTAGE TO MEASURING TERMINAL WHILE RANGE SWITCH IS IN OHM POSITION.

1. Set the selector switch to the appropriate Ω range to be used.
2. Connect the BLACK test lead to the "-COM" jack and the RED test lead to the Red "+" jack.
3. Short the leads by touching the probes together. Pointer should read zero at the right hand end of the upper most scale, if it doesn't, use the Ohm adjust knob on the right hand of the panel to line up the pointer with zero. (If pointer can't be brought to zero, replace battery.)
4. Connect the test leads across the resistance to be measured.
5. Take reading on the top " Ω " scale and multiply it by the multiplication factor indicated by the selector switch.
6. If there is little or no pointer movement from the left side of the scale, reset the selector switch to higher range. The effective reading scope on an Ohm meter scale is within the area of between 25 degree of Arc left side to the Midscale and 25 degree right side to the Midscale.

NOTE: If connected incorrectly with the voltage, this tester can be automatically restored to the normal working within 1 minute after taking off the test leads or the voltage load from the tester without any damage. (This tester can afford the voltage <250V DC/AC rms. for the period of 3 seconds max.)

Continuity Test



WARNING: DO NOT APPLY VOLTAGE TO MEASURING TERMINAL WHILE RANGE SWITCH IS IN OHM POSITION.

Set the selector switch to the BUZZ range. Connect the test leads to two points of circuit. If the resistance is lower than 200 Ohm approx., the Beeper sounds.

NOTE: Battery voltage is sufficient for Buzzer operation as long as the Zero Ohm pointer can be adjusted to the Zero scale place.

NOTE: If connected incorrectly with the voltage, quickly remove the test leads

from the circuit as to avoid damage to this tester.
(This tester can afford the voltage <250V DC/AC rms. for the period of 3 seconds max.)

Transistor hFE and LED Test

1. Set the selector switch to the R X 10 range.
FOR Measuring Transistor hFE
2. Take note the type of transistor "PNP" or "NPN" and then insert the transistor terminals of the Emitter, Base and Collector separately into the proper holes of the socket on the front panel.
3. Read the approximate hFE Value directly at the hFE scale.
NOTE: Current 10 μ A. VCE 2.8V.
4. When the Base terminal cut, the value of Leak is I_{ceo} for Transistor.
FOR Measuring LED: Insert the transistor terminals directly into the **E**(Up) "+" and **C**(Down) "-" holes of the socket on the front panel.
And then check if the LED under testing is lighting.

Diode Measurement

1. Set the selector switch to the appropriate Ω range to be used.
NOTE: To test the diode while current below 0.060 mA at X 10K range; current below 0.15 mA at X 1K range; current below 1.5 mA at X 100 range; current below 15 mA at X 10 range; current below 150 mA at X 1 range.
2. **For IF (forward current) test**, put the BLACK test lead to the "-COM" jack and the RED test lead to the Red "+" jack. And then connect the Black probe to the Positive terminal of the Diode, the Red probe to the Negative terminal of the Diode.
For IR (reverse current) test, reverse the connection.
3. Read the linear (forward voltage) VF of the diode on the LV scale.

Battery Check

1. This meter comes with two separate battery check ranges to test either DC 1.2V /2.0V /3.0V or 3.6V batteries.
 2. Set the selector switch to the appropriate BATT range to be used.
 3. Connect the BLACK test lead to the "-COM" jack and the RED test lead to the Red "+" jack.
 4. Connect the Red test lead to the positive end of battery and the Black one to the negative end of the battery to be measured.
 5. Take reading on the "BATT" scale and check it good or bad as per which portion indicated.
(**Note:** the mark section of "?" shows that the battery may be starting to decay.)
- NOTE:** If connected incorrectly with the voltage, quickly remove the test leads from the circuit and can avoid the damage to this tester.
(This tester can afford the voltage <250V DC/AC rms. for the period of 3 seconds max.)

Decibels Measurement

1. Set the selector switch to AC 10V range.
2. Connect the BLACK test lead to the "-COM" jack and the RED test lead to the Red "+" jack.
3. Connect the test leads to the measuring circuit specially in series with a 0.047 μ F/400V Metalized Polyester Capacitor. And then read the bottom Red dB scale.
4. For more dB scope, change the selector switch to the others of ACV ranges and make the same actions. Add the appropriate number of dB scale reading as noted on the chart below.

NOTE: For absolute dB measurements, circuit impedance must be 600 Ohm. 0 dB = 1mw dissipated in a 600 Ohm impedance (equivalent to 0.755V across 600 Ohm)

ACV RANGE	ADD dB Number
50	14
250	28
500	34
1000	40

Capacitance Measurement

WARNING: DO NOT APPLY VOLTAGE TO MEASURING TERMINAL WHILE MAKING ANY CAPACITANCE MEASUREMENTS.

BEFORE TESTING ANY CAPACITORS, DISCHARGE THE CAPACITOR COMPLETELY.

- 1) Set the selector switch to the C X1/X10/X100/X1K/X10K(R X10K/X1K/X100/X10/X1) range.
- 2) Connect the BLACK test lead to the "-COM" jack and the RED test lead to the Red "+" jack.
- 3) Connect the test leads to the capacitor to be measured (Note the polarity of capacitor).
- 4) Watch the needle deflection to the right topside, and read the Red C2000 μ F scale on the Dial.

TROUBLESHOOTING

Nevertheless, problems or malfunctions may occur.

For this reason, the following is a description of how you can eliminate possible malfunctions yourself:

Error	Possible cause
The multimeter does not work.	Are the batteries exhausted? Check the state of the batteries and the fuse 0.5A.
No measurements possible via V/mA socket.	Is the fuse defective? Check the fuse 0.5A (fuse replacement)

No measurements possible via 10A socket.	Is the fuse defective? Check the fuse 10A (fuse replacement)
No change in measured values.	Have you selected the right measuring sockets? Is the measuring range/mode correct (AC/DC)?
Faulty measuring results are displayed.	Has null balancing of the display or a 0 Ohm calibration for the resistance measurement been carried out? Is the batteries not properly assembled in?

MAINTENANCE

Replacement for Battery and/or Fuse should only be done after the test leads have been disconnected and POWER OFF.

1. Battery Replacement

- 1) This tester uses 2pcs AAA size 1.5V batteries which are located under the lower battery cover together with the big tilt device on the lower part of the rear case.
- 2) Note the condition of the batteries using the procedure described above, if the battery needs to be replaced, open the lower tilt device on the rear case and then turn the screw and take off the cover of the battery cabinet together with the tilt device on the rear case.
- 3) Remove the spent batteries and replace them with a battery of the same type. Observing polarity as indicated battery polarity marking on the bottom of the battery compartments.
- 4) Replace the battery cabinet cover and tighten the screw.

2. Fuse Replacement

- 1) When the fuse needs replacement, use only UL-Listed 0.5A/250V fuse or 10A/250V fuse identical in physical size to the original type $\Phi 5 \times 20$ mm.
- 2) Open the lower tilt device on the rear case and then turn the screw and take off the cover of the battery cabinet together with the tilt device.
- 3) The old fuses inside their holders located on the PCB can be visible and access to be removed. Then take off the melt fuses and install the new fuses into their original places.
- 4) Replace the battery cabinet cover and tighten the screw.

NOTE: 2pcs stand-by fuses are provided and located beside the batteries under the lower battery cover with rating marked below the fuses.

MT-2207 指針型防誤測三用電錶

操作使用說明書

特點：

本儀錶是指針式防誤測斜立型三用電錶(帶電晶體 LED 座，短路蜂鳴及 10A 檔)。具有如下參數和基本特點：

- 斜立型，後蓋斜立支撐架，支架可拉出轉動約 90 度支撐斜立。
- 後蓋下部是 1.5V 電池倉，用 PH1 十字起子拆卸和更換電池及保險管。
- 檔位切換簧片採用彈簧軸承及二極體雙向限幅電路。
- 配置玻璃纖維環氧樹脂鍍金 雙面電路板。
- 具有防誤測超載保護電路，速熔保險絲保護。
- 具有緊湊的兩側軟性防滑減振保護套。
- 可測直流電壓，直流電流（最大 10A），交流電壓，電阻，電晶體，二極體，LED，電池，短路蜂鳴，和電容等。
- 輸入阻抗：DC $\leq 50V$, 20Kohm/V; $> 50V$, 9Kohm/V ; AC 9Kohm/V
- 直流電壓：0.25/1/2.5/10/50/250/500/1000V(2500V)八檔
- 直流電流：50 μ A/0.5mA/5mA/50mA/500mA(10A)五檔
- 交流電壓：10/50/250/500/1000V(2500V)五檔
- 電阻：X1/X10/X100/X1K/X10K 五檔
- 電池：一檔
- 短路蜂鳴：一檔
- 電容：Cx1(Rx10K)/ Cx10(Rx1K)/ Cx100(Rx100)/ Cx1k(Rx10)/ Cx10k(Rx1)
- 標準環境條件：23°C \pm 5°C，濕度 < 75% RH。
- 工作環境範圍：0°C ~ 40°C，濕度 < 90% RH。
- 儲存條件：-10°C ~ 50°C，濕度 < 80% RH。
- 保險絲管：mA 檔，0.5A 250V 速熔保險絲；10A 檔，10A 250V 速熔保險絲
- 電池：2x1.5V AAA 電池
- 電錶外形尺寸：179（長）x 118（寬）x 50（高）mm
- 電錶重量：400 克（不包括電池和表筆）

規格表：

測試功能	檔位	準確度	說明
直流電壓 DCV	0-0.25V-1V-2.5V- 10V-50V-250V- 500V- 1000V(2500V)	$\pm 3\%$ FSD(滿刻度) $\pm 4\%$ FSD(1000V/2500 V 檔)	輸入阻抗：DC $\leq 50V$ 20K Ω /V; $> 50V$ 9K Ω /V 超載： 0.25V/1V/2.5V/10V/50V 各 檔, 250V Max. 250V/1000V 檔, 1000V Max. 2500V 檔, 2500V Max.

交流電壓 ACV	0-10V-50V-250V- 500V- 1000V(2500V)	±4%FSD(滿刻度) ±5%FSD(1000V/2500 V 檔) 頻率範圍： 40~10KHz	輸入阻抗：9KΩ/V 超載： 10V/50V 各檔, 250V Max. 250V/500V/ 1000V 各檔, 1000V Max. 2500V 檔, 2500V Max.
直流電流 DCA	0-50μA -0.5mA- 5 mA -50 mA - 500mA(10A)	±3%FSD(滿刻度) ±4%FSD(10A 檔)	壓降：250mV 超載保護： mA 檔：F0.5A 250V 保險絲 10A 檔：F10A/250V 保險 絲，大電流測試時間最多 10 秒。
電阻 Ω	X1:0.2~2KΩ (中值：20Ω) X10:2~20KΩ (中值：200Ω) X100:20~200KΩ (中值：2000Ω) X1K:200~2MΩ (中值：20KΩ) X10K:2K~20MΩ (中值：200KΩ)	±4%ofARC(弧長)	誤測：最高 AC/DC250V， 最大測試時間 3 秒，僅爆 保險絲管。
電容 Capacitance	Cx1: 50uF Cx10: 500uF Cx100: 5000uF Cx1K: 參考 Cx10K: 參考	僅供參考	誤測：最高 AC/DC250V， 最大測試時間 3 秒，僅爆 保險絲管。
電池測量 BATT Check	1.2V-2V-3V-3.6V: GOOD 綠 -?- BAD 紅	參考值	負載電阻：8-12Ω 誤測：最高 AC/DC250V， 誤測最大測試時間 3 秒， 僅爆保險絲管。
三極管檢測	hFE: 0-1000	參考值	使用 Ω×10 檔
LED, 二極管檢測		參考值	使用 Ω×10 檔；測試座 C,E 插孔,上“+”極,下“-”極
通斷測試	50 歐姆左右以 內，蜂鳴器會 響。		誤測：最高 AC/DC250V， 最大測試時間 3 秒，僅爆 保險絲管。
工作電源	1.5VAAA 電池: x2 節		

指針斜立型三用電錶指針閱讀參考表

測試 Test	量程檔位 Range Position	指標刻度讀數 Scale to read	倍數 Multiplied
電阻(歐姆) Resistance(Ω)	$\times 1$	Ω	$\times 1$
	$\times 10$		$\times 10$
	$\times 100$		$\times 100$
	$\times 1K$		$\times 1000$
	$\times 10K$		$\times 10000$
直流電壓 (伏特) DC Volt(V)	DC 0.25V	250	$\times 0.001$
	1 V	10	$\times 0.1$
	2.5V	250	$\times 0.01$
	10V	10	$\times 1$
	50V	50	$\times 1$
	250V	250	$\times 1$
	500V	50	$\times 10$
	1000V	10	$\times 100$
2500V	250	$\times 10$	
直流電流 (安培) DC Current (A)	DC $50 \mu A$	50	$\times 1$
	0.5mA	50	$\times 0.01$
	5mA	50	$\times 0.1$
	50mA	50	$\times 1$
	500mA	50	$\times 10$
10A	10	$\times 1$	
交流電壓 (伏特) AC Volt(V)	AC 10V	10	$\times 1$
	50V	50	$\times 1$
	250V	250	$\times 1$
	500V	50	$\times 10$
	1000V	10	$\times 100$
	2500V	250	$\times 10$
hFE	$\Omega \times 10$	IC/IB	$\times 1$
二極體 Diode	$\Omega \times 10K$		$\mu A \times 1$
	$\times 1K$		$\mu A \times 10$
	$\times 100$		$\mu A \times 100$
	$\times 10$		mA $\times 1$
	$\times 1$		mA $\times 10$

面板示意:

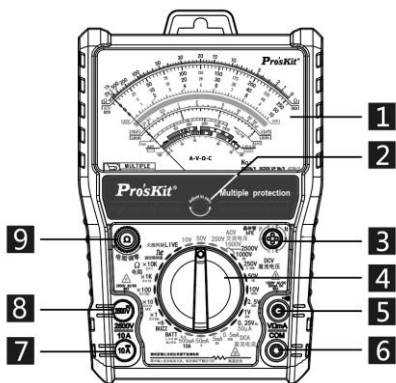

- 1.表盘 2.指针归零 3.hFE 测试插座 4.档位旋转开关 5.VΩmA 输入插座
6.COM 输入插座 7.10A 输入插座 8.2500V 输入插座 9.电阻调零

測量注意事項：

1. 指針調零
調整零位調整器，使指針和左側的零位對齊，不必每次測量前都調，但是在開始測量之前，指標都必須確認指標在零位上。
2. 測試棒的連接
紅色棒插“+”插孔，黑色棒插入“-COM”插孔。
3. 電錶內部電池檢查
將表棒按以上規定方式接入好，再將檔位旋鈕轉到 Rx10 檔位。然後，將表棒的兩端短路連接，檢查指針是否正常回歸零位，若不歸零，則電池電力不足，需更換新電池。
4. 量程的選擇
選擇測量檔位時，旋鈕上的“●”記號對準規定的適當量程。

測量工作方式：

1. 直流電壓：
用於測量電池、放大器電路、通訊設備電源、電子管和電晶體電路偏壓的直流電壓。每個檔位中的每一個檔位標記，分別表示該檔的最大電壓示值，1000V 和 2500V 共用檔位，2500V 電壓測量紅色表筆需要插在 2500V 測量孔位測量。
(※不確定之直流電壓，應從最大值依序向下調整量測)
2. 交流電壓：
用於測量商業交流電壓、交流電源電路、交流放大信號級等。每個檔位中的每一

個檔位標記，分別表示該檔的最大電壓示值，1000V 和 2500V 共用檔位，2500V 電壓測量紅色表筆需要插在 2500V 測量孔位測量。

(※不確定之交流電壓，應從最大值依序向下調整量測)

注意：使用 2500V 檔測量高壓時，必需雙手戴橡膠絕緣手套，並處於干燥絕緣的場地上才能測量。

4. 直流電流：(不可測量任何交流電流或電壓！)

用於測量直流電源控制裝置的電流消耗、電晶體電路的工作電流等。每個檔位中的每一個檔位標記，分別表示該檔的最大電流示值。

(※不確定之直流電流，應從最大值依序向下調整量測)

注意：當在 10A 檔測試大電流時，單次測試時間不能超過 10 秒。

而且兩次測試間隔時間不少於 5 分鐘。

本機電流檔位保險絲管超載保護，超載可能會熔斷保險絲管，mA 檔位測量超過 500mA 電流，會熔斷 F0.5A 250V 保險絲管，10A 檔位測量超過 10A 電流，會熔斷 F10A 250V 保險絲管。

5. 電阻：(※此功能不能測試帶電壓電路)

測量電阻值和測試線路和線路間的連通性。5 個檔中的每一個檔位標記，分別表示該檔乘數。(K 即 X1000)

注意：本機在此檔位誤測電壓可能會熔斷保險絲管。如不小心誤測熔斷，請更換同規格保險絲管。

6. 連通性測試(Buzz) (※此功能不能測試帶電壓電路)

將量程選擇旋鈕置於 Buzz 檔，當被測電路 $<50\Omega$ 左右，蜂鳴器鳴叫。

注意：本機在此檔位誤測電壓可能會熔斷保險絲管。如不小心誤測熔斷，請更換同規格保險絲管。

7. 電池測試：(一般電池正常電壓：AA 鎳氫/鎳鎘電池電壓 1.2V, AA 或 AAA 電池電壓 1.5V; CR2032 鈕扣電池電壓 3.0V, 一般鋰電池電壓 3.6V。)

好電池：指針停留在綠色(GOOD)範圍內。電量不足：指針停在“?”尚可使用範圍內。

壞電池：指標停在紅色(BAD)區域。

注意：本機在此檔位誤測市電電壓可能會熔斷保險絲管。如不小心誤測熔斷，請更換同規格保險絲管。

8. dB 測試 (在交流電壓檔測量)：

本機測量 dB 值時，要接入表棒並串接一個 $0.047\mu\text{F}/400\text{V}$ 電解電容，然後檢視電錶讀數。

測量在 10V 檔上進行，可直接讀取 dB 刻度(-10dB~+22dB)。

測量在 50V 檔上進行時，刻度讀值要加 14dB，才是實際 dB 值。

測量在 250V 檔上進行時，刻度讀值要加 28dB。

測量在 500V 檔上進行時，刻度讀值要加 34dB。

測量在 1000V 檔上進行時，刻度讀值要加 40dB。

例如，在 1000V 檔上最大可測 dB 值是 $22+40=62\text{dB}$ 。

9. hFE(直流放大倍數)和發光二極體(LED)測試：

將量程選擇旋鈕置於“電阻”檔之 X10 檔 (hFE)

hFE 測試：

- (1) 調節 0 Ω 調整器使指針和零位對齊-將電晶體的三個管腳直接插入面板上的 hFE 端座。

(※注意區分電晶體的類別“PNP”和“NPN”)

- (2) 在 hFE 刻度讀出顯示值，所讀之值是 IC/IB，即被測體的直流放大倍數。

LED 測試：

- (1) 將 LED 的兩腳按正負極性直接插入三極管插座的上 (+)、下 (-) 兩個孔。
- (2) 檢查 LED 是否正常發光。

10. 二極體測試：

- (1) 將量程選擇旋鈕置於“ Ω ”檔上有選擇的量程位置，X10K 用於 0-60 μ A 測試，X1K 用於 0-150 μ A，X100 用於 0-1.5mA，X10 於 0-15mA，X1 用於 0-150mA 測試。
- (2) 將電錶與二極體連接，電錶的“COM”端與二極體陽極相連，“+”端與二極體陰極相連，測 IF(正向電流)，對於 IR(反向電流)測試連接方法和 IF 相反。
- (3) 在測試 IF 或 IR 同時在 LV 刻度上，讀出二極體正向(反向)電壓。

11. 電容測試：

注意：檢測前，須將電容放電並將電錶調零。(※此功能不能測試帶電壓電路)

- a. 將電錶量程選擇旋鈕置於“ Ω 相應”檔位。
- b. 用表棒連接電容，並注意“+”，“-”極性。
- c. 觀察指標偏轉最大時，電錶刻度板上綠色 C 刻度。

常見問題故障及處理

若用戶在使用中，發現本機出現一些普通常見問題故障，可參照下表自行進行分析處理：

問題和故障	原因和處置
指針無反應，不動	表棒是否接觸良好？ 內部保險管是否燒斷？ 內部電池是否正確裝好，並接觸到？ (參閱有關電池和保險管更換說明)
指針指示異常	檔位量程是否選擇正確？交流和直流模式是否使用正確？ 內部電池是否電量不足？(參閱有關電錶內部電池檢查說明)
指針無法正常歸零位	內部電池是否接觸良好？是否電量不足？(參閱有關電錶內部電池檢查說明) 內部機芯處的遊絲是否並圈？可試用力將本機甩動幾下或在手中拍擊幾下後，看是否恢復正常。
DC 電流檔不能工作	表棒是否接觸良好，正確接入？ 內部保險管是否裝好或燒斷？ (參閱有關保險管更換說明)

日常維修

維修更換電錶內部電池和保險絲管時，必須將表棒從電錶上移調，並切斷電源。

1). 1.5V 電池更換：

打開電錶後面下部支撐架，用 PH1 起子旋開螺絲，將電池倉後蓋連支撐架卸下，然後從電池座中拿出舊的電池。再將新的同規格電池放入原位，並注意電池的正負極性，然後蓋上後蓋並鎖住螺絲。

2). 保險絲管更換：

打開電錶後面的下部支撐架，用 PH1 十字起子旋開螺絲，將電池倉後蓋連支撐架卸下，即可看到裡面蓋子上的兩個並列備用保險管（F0.5A/250V F10A/250V， $\Phi 5*20\text{mm}$ ），從保險絲座中拿出不好的保險絲管。再將新保險絲管換上，**必須用同規格 UL 認證的保險絲管**，然後，蓋上後蓋並鎖上螺絲。

（本電錶的電池倉的右邊一般有 2 個備用保險絲管）。

MT-2207 指针型防误测三用电表

操作使用说明书

特点:

本仪表是指针式防误测斜立型三用电表(带晶体 LED 座, 短路蜂鸣及 10A 档)。具有如下参数和基本特点:

- 斜立型, 后盖斜立支撑架, 支架可拉出转动约 90 度支撑斜立。
- 后盖下部是 1.5V 电池仓, 用 PH1 十字起子拆卸和更换电池及保险管。
- 档位切换簧片采用弹簧轴承及二极管双向限幅电路。
- 配置玻璃纤维环氧树脂镀金 双面电路板。
- 具有防误测超载保护电路, 速熔保险丝保护。
- 具有紧凑的两侧软性防滑减振保护套。
- 可测直流电压, 直流电流 (最大 10A), 交流电压, 电阻, 晶体管, 二极管, LED, 电池, 短路蜂鸣, 和电容等。
- 输入阻抗: DC $\leq 50V$, 20Kohm /V; $> 50V$, 9Kohm/V ; AC 9Kohm/V
- 直流电压: 0.25V/1/2.5/10/50/250/500/1000V (2500V) 八档
- 直流电流: 50 μ A/0.5mA/5mA/50mA/500mA (10A) 五档
- 交流电压: 10/50/250/500/1000V (2500V) 五档
- 电阻: X1/X10/X100/X1K/X10K 五档
- 电池: 一档
- 短路蜂鸣: 一档
- 电容: Cx1 (Rx10K) / Cx10 (Rx1K) / Cx100 (Rx100) / Cx1k (Rx10) / Cx10k (Rx1)
- 标准环境条件: 23°C \pm 5°C, 湿度 < 75% RH。
- 工作环境范围: 0°C ~ 40°C, 湿度 < 90% RH。
- 储存条件: -10°C ~ 50°C, 湿度 < 80% RH。
- 保险丝管: mA 档, 0.5A 250V 速熔保险丝; 10A 档, 10A 250V 速熔保险丝
- 电池: 2x1.5V AAA 电池
- 电表外形尺寸: 179 (长) x 118 (宽) x 50 (高) mm
- 电表重量: 400 克 (不包括电池和表笔)

规格表:

测试功能	档位	准确度	说明
直流电压 DCV	0.25V-1V-2.5V- 10V-50V-250V- 500V- 1000V (2500V)	$\pm 3\%$ FSD (满刻度) $\pm 4\%$ FSD (1000V/ 2500V 档)	输入阻抗: DC $\leq 50V$ 20K Ω /V; $> 50V$ 9K Ω /V 超载: 0.25V/1V/2.5V/10V/50V 各 档 250V Max; 250V/1000V 档, 1000V Max.

			2500V 档, 2500V Max.
交流电压 ACV	10V-50V-250V- 500V- 1000V (2500V)	±4%FSD(满刻度) ±5%FSD(1000V/2 500V 档) 频率范围: 40~10KHz	输入阻抗: 9K Ω /V 超载: 10V/50V 档, 250V Max; 250V/500V/ 1000V 各档, 1000V Max. 2500V 档, 2500V Max.
直流电流 DCA	50 μ A -0.5mA- 5 mA-50 mA - 500mA, 10A	±3%FSD(满刻度) ±4%FSD(10A 档)	压降: 250mV 超载保护: mA 档: F0.5A/250V 保险丝 10A 档: F10A/250V 保险 丝, 大电流测试时间最多 10 秒。
电阻 Ω	X1:0.2~2K Ω (中值: 20 Ω) X10:2~20K Ω (中值: 200 Ω) X100:20~200K Ω (中值: 2000 Ω) X1K:200~2M Ω (中值: 20K Ω) X10K:2K~20M Ω (中值: 200K Ω)	±4% of ARC(弧 长)	误测: 最高 AC/DC250V, 超载最大测试时间 3 秒, 仅爆保险丝管。
电容 Capacitance	C: 最大值 Cx1: 50uF Cx10: 500uF Cx100: 5000uF Cx1K: 参考 Cx10K: 参考	仅供参考	误测: 最高 AC/DC250V, 超载最大测试时间 3 秒, 仅爆保险丝管。
电池测量 BATT Check	1.2-2-3-3.6V: GOOD 绿 -?-BAD 红	参考值	负载电阻: 8-12 Ω 误测: 最高 AC/DV250V, 误测最大测试时间 3 秒, 仅爆保险丝管。
三极管检测	hFE: 0-1000	参考值	使用 $\Omega \times 10$ 档
LED, 二极管检测		参考值	使用 $\Omega \times 10$ 档; 测试座 C, E 插孔, 上 “+” 极, 下 “-” 极
通断测试	50 欧姆左右以 内, 蜂鸣器会响。		误测: 最高 AC/DC 250V, 误测最大测试时间 3 秒。
内部电源	1.5VAAA 电池: 2 节		

指针斜立型三用电表指针阅读参考表

测试 Test	量程档位 Range Position	指标刻度读数 Scale to read	倍数 Multiplied
电阻(欧姆) Resistance(Ω)	$\times 1$ $\times 10$ $\times 100$ $\times 1K$ $\times 10K$	Ω	$\times 1$ $\times 10$ $\times 100$ $\times 1000$ $\times 10000$
直流电压 (伏特) DC Volt(V)	DC 0.25V 1 V 2.5V 10V 50V 250V 500V 1000V 2500V	250 10 250 10 50 250 50 10 250	$\times 0.001$ $\times 0.1$ $\times 0.01$ $\times 1$ $\times 1$ $\times 1$ $\times 10$ $\times 100$ $\times 10$
直流电流 (安培) DC Current (A)	DC 50 μ A 0.5mA 5mA 50mA 500mA 10A	50 50 50 50 50 10	$\times 1$ $\times 0.01$ $\times 0.1$ $\times 1$ $\times 10$ $\times 1$
交流电压 (伏特) AC Volt(V)	AC 10V 50V 250V 500V 1000V 2500V	10 50 250 50 10 250	$\times 1$ $\times 1$ $\times 1$ $\times 10$ $\times 100$ $\times 10$
hFE	$\Omega \times 10$	IC/IB	$\times 1$
二极管 Diode	$\Omega \times 10K$ $\times 1K$ $\times 100$ $\times 10$ $\times 1$		μ A $\times 1$ μ A $\times 10$ μ A $\times 100$ mA $\times 1$ mA $\times 10$

面板示意

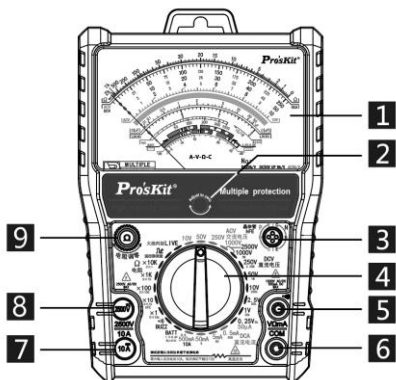

1. 表盘 2. 指针归零 3. hFE 测试插座 4. 档位旋转开关
5. V Ω mA 输入插座 6. COM 输入插座 7. 10A 输入插座
8. 2500V 输入插座 9. 电阻调零

测量注意事项:

1. 指针调零
调整零位调整器，使指针和左侧的零位对齐，不必每次测量前都调，但是在开始测量之前，指标都必须确认指针在零位上。
2. 测试棒的连接
红色棒插“+”插孔，黑色棒插入“-COM”插孔。
3. 电表内部电池检查
将表棒按以上规定方式接入好，再将档位旋转到 Rx10 档位。然后将表棒的两端短路连接，同时调整调零旋钮，检查指针是否正常回归零位。若不能，则电池电力不足，应要更换新电池。
4. 量程的选择
选择测量档位时，旋钮上的“●”记号对准规定的适当量程。

测量工作程序:

1. 直流电压：
用于测量电池、放大器电路、通讯设备电源、电子管和晶体管电路偏压的直流电压。每个档位中的每一个位置标记，分别表示该档位的最大电压示值。
(※不确定之直流电压，应从最大值依序向下调整量测)
3. 交流电压：
用于测量商业交流电压、交流电源电路、交流放大信号级等。每个档位中的每一

个位置标记，分别表示该档位的最大电压示值。(※不确定之交流电压，应从最大值依序向下调整量测)

注意：使用 2500V 档测量高压时，必需双手戴橡胶绝缘手套，并处于干燥绝缘的场地上才能测量。

4. 直流电流：(不可测量任何交流电流或电压！)

用于测量直流电源控制装置的电流消耗、晶体管电路的工作电流等。每个档位中的每一个档位标记，分别表示该档位的最大电流示值。

(※不确定之直流电流，应从最大值依序向下调整量测)

注意：当在 10A 档测试大电流时，单次测试时间不能超过 10 秒。

而且两次测试间隔时间不少于 5 分钟。

本机电流档位保险丝管过载保护，超载，可能会熔断保险丝管，mA 档位超过测量超过 500mA 电流，可能会熔断 F0.5A 250V 保险丝管，10A 档测量超过 10A，熔断 F10A 250V 保险丝管。

5. 电阻：(※此功能不能测试带电压电路)

测量电阻值和测试线路和线路间的连通性。每个档位中的每一个档位标记，分别表示该文件乘数。(K 即 X1000)

注意：本机在电阻档位误测电压可能会熔断保险丝管。如不小心误测熔断，请更换同规格保险管。

6. 连通性测试(Buzz) (※此功能不能测试带电压电路)

将量程选择旋钮置于 Buzz 档，当被测电路 $<50\Omega$ ，蜂鸣器鸣叫。

注意：本机在蜂鸣档位误测电压可能会熔断保险丝管。如不小心误测熔断，请更换同规格保险管。。

7. 电池测试：(※一般电池正常电压：AA 镍氢/镍铬电池电压 1.2V, AA 或 AAA 普通电池电压 1.5V;CR2032 纽扣电池电压 3.0V, 一般锂电池电压 3.6V。)

好电池：指针停留在绿色(GOOD)范围内。电量不足：指针停在“?”尚可使用范围内。

坏电池：指针停在红色(BAD)区域。

注意：本机在本档位误测市电电压可能会熔断保险丝管。如不小心误测熔断，请更换同规格保险管。

8. dB 测试：

本机测量 dB 值时，要接入表棒并串接一个 $0.047\mu\text{F}/400\text{V}$ 电解电容，然后检视电表读数。

测量在 10V 档上进行，可直接读取 dB 刻度(-10dB~+22dB)。

测量在 50V 档上进行时，刻度读值要加 14dB，才是实际 dB 值。

测量在 250V 档上进行时，刻度读值要加 28dB。

测量在 500V 档上进行时，刻度读值要加 34dB

测量在 1000V 档上进行时，刻度读值要加 40dB。

例如，在 1000V 档上最大可测 dB 值是 $22+40=62\text{dB}$ 。

9. hFE(直流放大倍数)和发光二极管(LED)测试：

将量程选择旋钮置于“OHM”档上之 X10 档

hFE 测试：

- 1) 调节 $0\ \Omega$ 调整器使指针和零位对齐-将晶体管的三个管脚直接插入面板上的 hFE 插座。

(※注意区分晶体管的类别“PNP”和“NPN”)

- 2) 在 hFE 刻度读出显示值, 所读之值是 IC/IB, 即被测体的直流放大倍数。

LED 测试:

- 1) 将 LED 的两个脚按正负极性直接插入三极管的上 (+)、下 (-) 两个孔位。
- 2) 检查 LED 是否正常发光。

10. 二极管测试:

- 1) 将量程选择旋钮置于“ Ω ”档上有选择的量程位置, X10K 用于 $0\sim 60\ \mu\text{A}$ 测试, X1K 用于 $0\sim 150\ \mu\text{A}$, X100 用于 $0\sim 1.5\text{mA}$, X10 于 $0\sim 15\text{mA}$, X1 用于 $0\sim 150\text{mA}$ 测试。
- 2) 将电表与二极管连接, 电表的“COM”端与二极管阳极相连, “+”端与二极管阴极相连, 测 IF(正向电流), 对于 IR(反向电流)测试连接方法和 IF 相反。
- 3) 在测试 IF 或 IR 同时在 LV 刻度上, 读出二极管正向(反向)电压。

11. 电容测试:

注意: 检测前, 须将电容放电并将电表调零。(※此功能不能测试带电压电路)

- a. 将电表量程选择旋钮置于电阻档相应档位。
- b. 用表棒连接电容, 并注意“+”, “-”极性。
- c. 观察指标偏转最大时, 电表刻度板上绿色 C 刻度。

常见问题故障及处理

若用户在使用中, 发现本机出现一些普通常见问题故障, 可参照下表自行进行分析处理:

问题和故障	原因和处置
指针无反应, 不动	表棒是否接触良好? 内部保险管是否烧断? 内部电池是否正确装好, 并接触到位? (参阅有关电池和保险管更换说明)
指针指示异常	档位量程是否选择正确? 交流和直流模式是否使用正确? 内部电池是否电量不足? (参阅有关电表内部电池检查说明)
指针无法正常归零位	内部电池是否接触良好? 是否电量不足? (参阅有关电表内部电池检查说明) 内部机芯处的游丝是否并圈? 可试用力将本机甩动几下或在手中拍击几下后, 看是否恢复正常。
直流电流档不能工作	表棒是否接触良好, 正确接入? 内部保险管是否装好或烧断? (参阅有关保险管更换说明)

日常维修

维修更换电表内部电池和保险丝管时，必须将表棒从电表上移走，并切断电源。

1). 1.5V 电池更换：

打开电表后面下部支撑架，用 PH1 起子旋开螺丝，将电池仓后盖连支撑架卸下，然后从电池座中拿出旧的电池。再将新的同规格电池放入原位，并注意电池的正负极性，然后盖上后盖并锁上螺丝。

2). 保险丝管更换：

打开电表后面的下部支撑架，用 PH1 十字起子旋开螺丝，将电池仓后盖连支撑架卸下，即可看到里面盖子上的两个并列备用保险管 (F0.5A 250V;10A 250V)，从保险丝座中拿出不好的保险丝管，**再将同规格新保险丝管换上，必须用同规格 UL 认证的保险丝管**，然后，盖上后盖并锁上螺丝。

(本电表的电池仓的右边一般有 2 个备用保险丝管)。

Pro'sKit® 中国地区产品保固卡

购买日期		店章
公司名称		
联络电话		
电子邮箱		
联络地址		
产品型号	<input type="checkbox"/> MT-2207-C	

- ※ 在正常使用情况下，自原购买日起 12 个月免费维修保证(不含耗材、消耗品)。
- ※ 产品保固卡需盖上店章、日期章，其保固效力始生效。
- ※ 本卡请妥善保管，如需维修服务时，请出示本卡以为证明。
- ※ 保固期满后，属调整、保养或是维修性质之服务，则酌收检修工时费用。若有零件需更换，则零件费另计。

产品保固说明

- 保固期限内，如有下列情况者，维修中心则得酌收材料成本或修理费(由本公司维修人员判定):
 - 对产品表面的损伤，包括外壳裂缝或刮痕
 - 因误用、疏忽、不当安装或测量，未经授权打开产品修理，修改产品或者任何其它超出预期使用范围的原因所造成的损害
 - 因事故、火灾、电力变化、其它危害，或自然灾害所造成的损害。
- 非服务保证内容：
 - 本体外之消耗品：如电池、保险丝管等消耗品
 - 本体之外及配件：如表笔等配件。
- 超过保证期限之检修或服务，虽未更换零件，将依公司保固维修政策酌收服务费。

制造商：宝工实业股份有限公司

地址：台湾台北新北市新店区民权路 130 巷 7 号 5 楼

电话：886-2-22183233

E-mail: pk@mail.prokits.com.tw

销售/生产商：上海宝工工具有限公司

地址：上海市浦东新区康桥东路 1365 弄 25 号

电话：021-68183050

原产地：中国 上海

服务热线：400 1699 629

Pro'sKit[®]

ISO 9001
CERTIFIED



寶工實業股份有限公司
PROKIT'S INDUSTRIES CO., LTD

<http://www.prokits.com.tw>

E-mail: pk@mail.prokits.com.tw

©2023 Copyright by Prokit's Industries Co., LTD. All rights reserved

2023001(A)