

本體	螺絲
材質	材質
PE	SUS
UHMWPE	

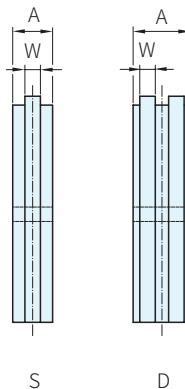
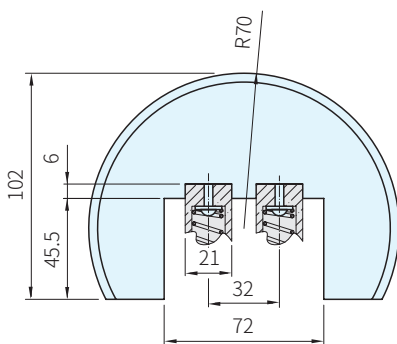

品 號	Code	鏈 條	A	W	質 量 (kg)	庫 存
TC-CR1S	BL010711	06B	30	5	0.40	•
TC-CR2S	BL010712	08B		7	0.41	•
TC-CR3S	BL010713	10B		9	0.43	•
TC-CR4S	BL010714	12B		11	0.44	•
TC-CR5S	BL010715	16B		16	0.45	•
TC-CR1D	BL010721	06B		5	0.41	•
TC-CR2D	BL010722	08B		7	0.42	•
TC-CR3D	BL010723	10B		9	0.44	•
TC-CR4D	BL010724	12B		11	0.45	•

Ps. 備註

- 工作速度 ≤ 20 m/min
- 工作溫度 ≤ 70°C
- 適用於180°的纏繞角度

Ex. 使用例

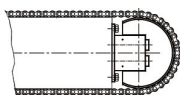

訂貨： 交期：

TC-CR1S

Wa. 注意

- 和TC-BC組立使用

