

Body
A5052 aluminum alloy
Anodized
Natural

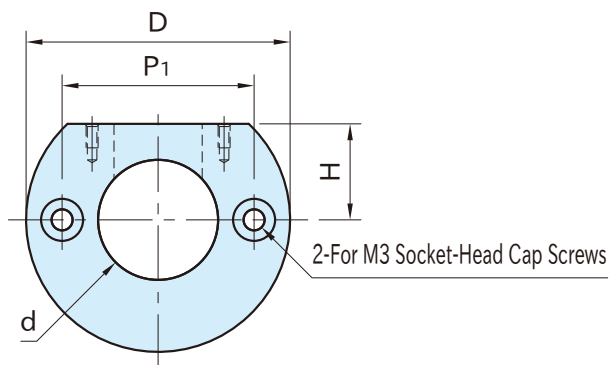

Part Number	d (F8)	H	D	L	P	M	d <sub>1</sub>	P <sub>1</sub>	L <sub>1</sub>	Shaft Dia. *)
<b>QCPSC0828-20</b>	20	16	44	20	22	M2×0.4 Depth 4	14.7	32	16	φ 20
<b>QCPSC0828-25</b>	25	18.5	48					36		φ 25
<b>QCPSC1036-20</b>	20	16	50	24	28	M3×0.5 Depth 6	17.7	36	20	φ 20
<b>QCPSC1036-25</b>	25	18.5	52					38		φ 25

\*) Recommended shaft tolerance is JIS f8, g6, h5-h9.

Part Number	Weight (g)	Proper One Touch Push Lock Clamp	
<b>QCPSC0828-20</b>	55	<b>QCPS-OG-F</b>	0828-6
		<b>QCPS-BK-F</b>	
<b>QCPSC0828-25</b>	62	<b>QCPS-S-F</b>	
<b>QCPSC1036-20</b>	86	<b>QCPS-OG-D</b>	1036-6
		<b>QCPS-BK-D</b>	
<b>QCPSC1036-25</b>	88	<b>QCPS-S-D</b>	

### Supplied With

- **QCPSC0828-20** **QCPSC0828-25**:  
2 of socket-head cap screw (stainless steel), M3×0.5-20L
- **QCPSC1036-20** **QCPSC1036-25**:  
2 of socket-head cap screw (stainless steel), M3×0.5-25L

