

**Constructional features (Type A)**

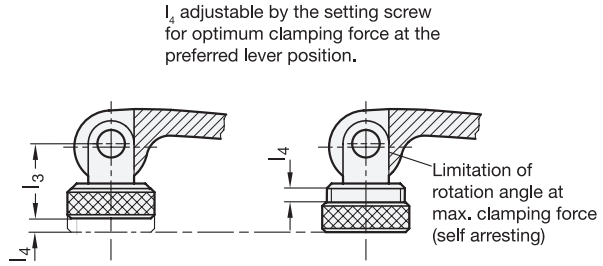

$l_4$  must not be exceeded. Otherwise there is the risk that the positioning thread can no longer absorb the clamping force or may be damaged.

**Application example**

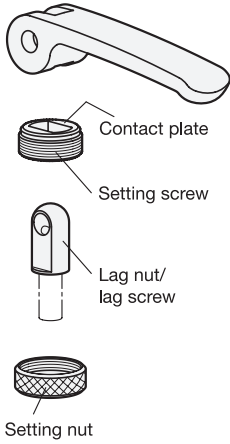
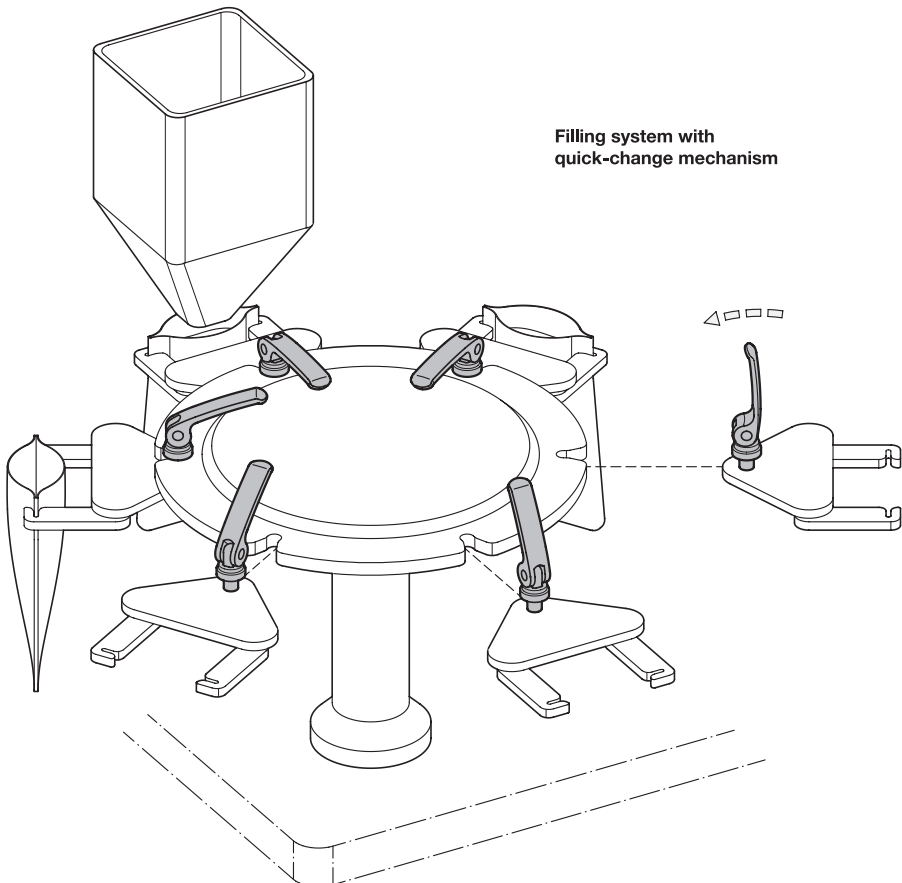

1.1  
1.2  
1.3  
1.4  
2.1  
2.2  
2.3  
2.4