

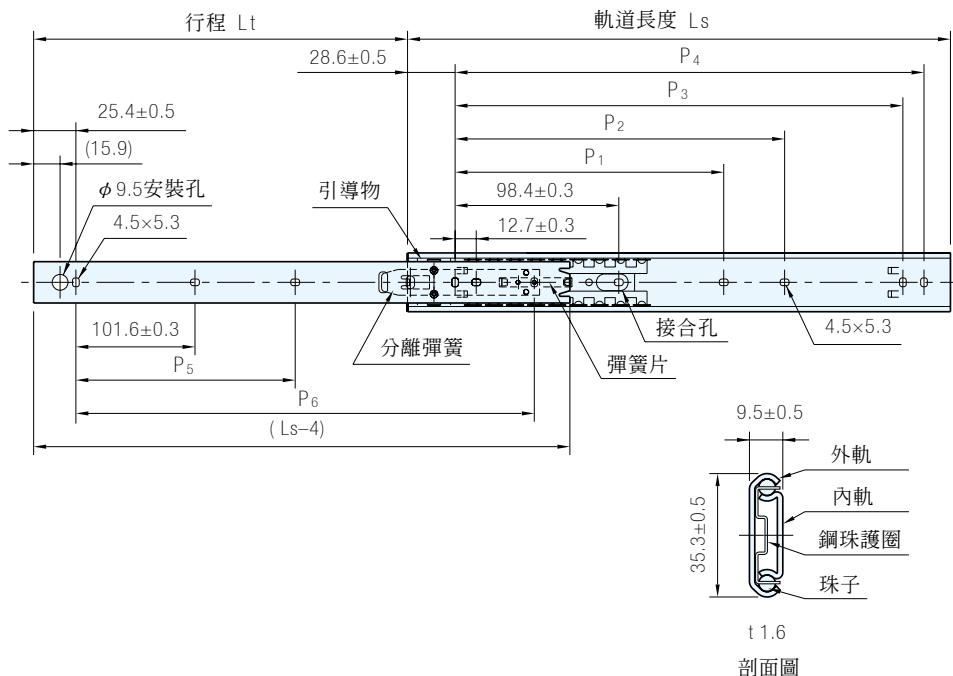

內軌	鋼珠護圈	珠子
外軌		
材質	處理	材質
SPCC	鍍鋅	SECC
		碳鋼



品號	L _s (±0.8)	L _t (±3)	P ₁ (±0.3)	P ₂ (±0.3)	P ₃ (±0.3)	P ₄ (±0.3)	P ₅ (±0.3)	P ₆ (±0.3)	額定荷重 (N/2pcs)	質量 (g/支)	庫存
RS35S-12M	304.8	224	136.5	-	247.6	260.3	152.4	-	490	300	•
RS35S-14M	355.6	275	187.3	-	298.4	311.1	203.2	-	400	360	•
RS35S-16M	406.4	315	238.1	-	349.2	361.9	254.0	-	390	420	•
RS35S-18M	457.2	330	200.0	288.9	400.0	412.7	203.2	406.4	380	480	•
RS35S-20M	508.0	381	225.4	339.7	450.8	463.5	228.6	457.2	330	520	•
RS35S-22M	558.8	406	250.8	390.5	501.6	514.3	254.0	508.0	320	580	•
RS35S-24M	609.6	432	276.2	441.3	552.4	565.1	279.4	558.8	310	620	•
RS35S-26M	660.4	483	301.6	492.1	603.2	615.9	304.8	609.6	280	680	•
RS35S-28M	711.2	493	327.0	542.9	654.0	666.7	330.2	660.4	270	740	•

Sp. 特長

- 此滑軌是分離手動型,軌道完全拉出時,內軌被鎖固,按下分離彈簧,鎖固解除,內軌可以拆卸,插入時亦同

訂貨： 交期：

RS35S-12M

Wa. 注意

- 安裝螺栓請使用TDJ·TDJS·BBRSS·BRSS(螺絲螺帽單元)
- 內軌可以拆卸
- 有部份產品未符合RoHS,請洽詢