

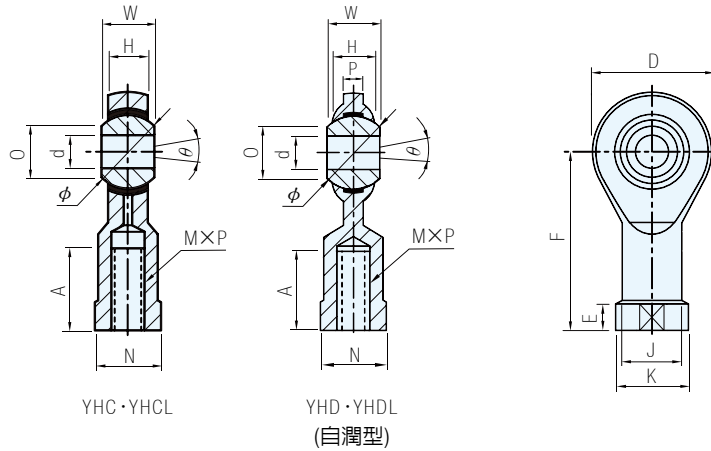

Type	本體		鋼珠		嵌入材
	材質	處理	材質	處理	材質
YHC · YHCL	S35C	鍍鋅	SUJ2 (HRC58)	鍍鉻	特殊銅合金
YHD · YHDL					鐵氟龍銅網



品號	d	W	O	H ⁺⁰ / _{-0.1}		D	F	A	J	K	E	P	N	M×P	旋角 θ	球徑 φ	荷重 YHC YHCL (kgf)	荷重 YHD YHDL (kgf)	單價				
				YHC YHCL	YHD YHDL														YHC	YHCL	YHD	YHDL	
YHC YHD (右牙)	4	4	7	7.6	—	5.3	14	24	12	8	9.5	4	4	8	M 4×0.7	13	10.32	—	220			•	•
	5	5	8	7.7	6	5.5	17	27		9	11			9	M 5×0.8		11.11	560	390	•	•	•	•
	6	6	9	8.9	6.7	6	19	30	14	10	13			11	M 6×1	12.7	690	500					
	8	8	12	10.4	9	8	23.5	36	17	13	16	5	5	14	M 8×1.25	15.88	980	740	•	•	•	•	
	8F													M 8×1									
	10	10	14	12.9	10.5	10	27	45	21	15	19	7	7	17	M10×1.5	19.05	1320	940	•	•	•	•	
	10F													M10×1.25									
	12	12	16	15.4	12	11	32	50	24	18	22	7	7	19	M12×1.75	22.23	1670	1100	•	•	•	•	
	12F													M12×1.25									
	YHCL YHDL (左牙)	14	14	19	16.8	14	12	36	57	27	20	25	8	8	21	M14×2	25.4	2060	1520	•	•	•	•
14F		M14×1.5																					
16		16	21	19.3	15	13	39	64	33	22	27	8	8	22	M16×2	28.58	2500	2020	•	•	•	•	
16F														M16×1.5									
18		18	23	21.8	17	15	44	71	36	25	31	10	10	27	M18×1.5	31.75	2940	2520	•	•	•	•	
20														30	M20×1.5								34.93
22		22	28	25.9	20	18	50	84	43	30	37	12	12	32	M22×1.5	38.1	4120	3590					
25														36	M24×2								42.85
30	30	37	34.8	26	24	67	111	56	40	50	15	15	41	M30×2	50.8	9210	6910						

【Ps.】備註

- ・不銹鋼材質歡迎洽詢
- ・交期請先洽詢

訂貨： 交期： 天

YHC3