

附快速接頭調速閥

L型 / 萬向型

AS Series



型式

型式		配管口徑	密封方式	適用配管外徑														
L型	萬向型			公釐尺寸						英吋尺寸								
				2 ^{註2)}	3.2	4	6	8	10	12	16	1/8"	5/32"	1/4"	5/16"	3/8"	1/2"	
AS12□1F-M5□	AS13□1F-M5□	M5×0.8	墊片 密封	● ^{註3)}	●	●	●					●	●	●				
AS12□1F-U10/32□	AS13□1F-U10/32□	10-32UNF		● ^{註3)}	●	●	●						●	●	●			
AS22□1F-□01	AS23□1F-□01	R NPT	密封劑 ^{註1)}		●	●	●	●	● ^{註3)}			●	●	●	●			
AS22□1F-□02	AS23□1F-□02			1/8		● ^{註3)}	●	●	●	●			● ^{註3)}	●	●	●	●	
AS32□1F-□02	AS33□1F-□02			1/4			●	●	●	●				●	●	●	●	
AS32□1F-□03	AS33□1F-□03			3/8			●	●	●	●				●	●	●	●	
AS42□1F-□04	AS43□1F-□04			1/2						●	●	● ^{註3)}				●	●	●

註1) 也可選擇密封劑。
 註2) ø2的適用配管材質,只限聚氨酯管。
 註3) 沒有萬向型。

規格

本體的流動方向的記號的表示

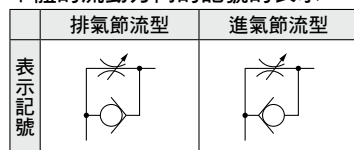

使用流體	空氣
保証耐壓力	1.5MPa
最高使用壓力	1MPa
最低使用壓力	0.1MPa
周圍溫度及使用流體溫度	-5~60°C(不結冰)
適用配管材質	尼龍、軟尼龍、聚氨酯 ^{註)} 、FEP、PFA

註) 請注意軟尼龍聚氨酯的最高使用壓力。
 (詳細請參照網頁WEB目錄或Best Pneumatics No.⑥)

流量及音速傳導

注意

使用的前請務必詳讀。
 有關安全上的注意事項請確認封底上的內容、驅動控制機器 / 共通注意事項,請確認「SMC產品操作注意事項」。
<http://www.smcworld.com>

型式	AS12□1F-M5□ AS13□1F-M5□		AS22□1F-□01 ^{註3)} AS23□1F-□01 ^{註3)}			AS22□1F-□02 AS23□1F-□02			AS32□1F AS33□1F			AS42□1F AS43□1F		
	公釐尺寸	英吋尺寸	ø2	ø3.2	ø4	ø6	ø8	ø10	ø3.2	ø4	ø6	ø8	ø10	ø12
配管外徑	ø2	ø1/8" ø5/32"	ø2	ø3.2	ø4	ø6	ø8	ø10	ø3.2	ø4	ø6	ø8	ø10	ø12
C值:音速傳導 dm³/(s·bar)	0.2	0.3	0.4	0.6	0.6	0.7	1.0	1.3	1.5	1.6	1.7	2.5	4.4	4.8
b值:臨界壓力比	0.3	0.4	0.2	0.3	0.3	0.3	0.4	0.4	0.3	0.3	0.3	0.3	0.3	0.3

註1) 10-32UNF為M5相同。
 註2) C值, b值為控制流向的全開狀態及自由流向的針閥全閉狀態的值。
 註3) AS-FG系列(不鏽鋼規格)也相同。



型號表示方法

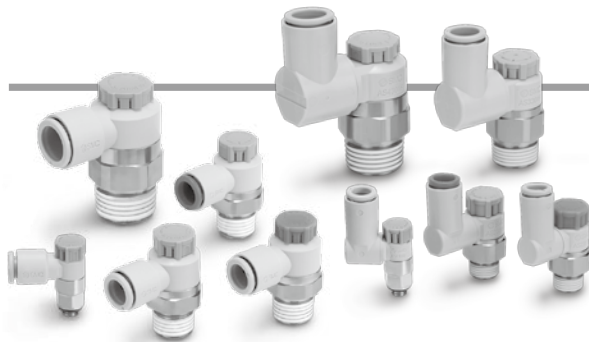

本體尺寸

1	M5×0.8 10-32UNF
---	--------------------

六角對邊(H)尺寸

E	8mm
無記號	9mm

六角對邊(H)尺寸

適用配管外徑^{註1)}

公釐尺寸		英吋尺寸	
02	ø2	01	ø1/8"
23	ø3.2 ^{註2)}	03	ø5/32"
04	ø4	07	ø1/4"
06	ø6		

註1) 適用配管外徑的選定為型式(P.5)做確認。
 另外,公釐尺寸-英吋尺寸的外觀識別為釋放套的顏色作區別。
 公釐尺寸:淺灰色
 英吋尺寸:橘色
 註2) 請使用ø1/8"的管子。

本體尺寸1

AS 1 2 0 1 F - M5 E - 06

本體尺寸2-3-4

AS 2 2 0 1 F - 01 - 06 S A -

本體尺寸

2	1/8, 1/4
3	3/8
4	1/2

型式

2	L型
3	萬向型

控制方式^{註)}

0	排氣節流
1	進氣節流

註) 排氣節流、進氣節流的外觀識別由握把的顏色識別來區別。
 排氣節流:銀灰色
 進氣節流:淺藍色

螺牙的種類

無記號	R
N	NPT

● 連接口徑

01	1/8
02	1/4
03	3/8
04	1/2

● 適用配管外徑^{註1)}

公釐尺寸		英吋尺寸	
23	ø3.2 ^{註2)}	01	ø1/8"
04	ø4	03	ø5/32"
06	ø6	07	ø1/4"
08	ø8	09	ø5/16"
10	ø10	11	ø3/8"
12	ø12	13	ø1/2"
16	ø16		

註1) 適用配管外徑的選定,請由組合變化表(P.5)做確認。
 註2) 請使用ø1/8"的管子。

● 訂製品規格
 詳細請參照P.14。

● 壓下鎖定式

● 密封方式

無記號	無密封劑
S	附密封劑

AS
 AS-FG
 Uni-AS
 密封劑/墊片
 密封圈密封
 墊片密封

AS Series

針閥 / 流量特性

AS1201F-M5□, AS1211F-M5□
AS1301F-M5□, AS1311F-M5□

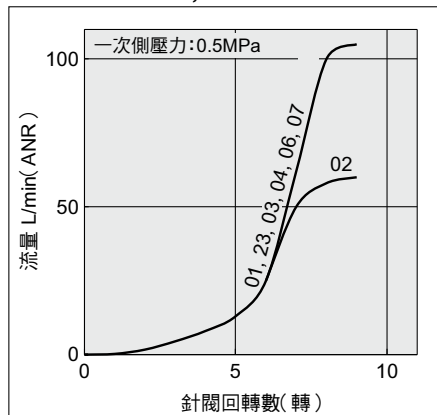

註) -U10/32與M5相同。

AS2201F-01, AS2211F-01
AS2301F-01, AS2311F-01

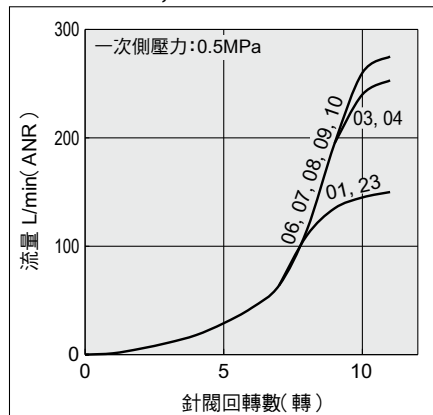

AS2201F-02, AS2211F-02
AS2301F-02, AS2311F-02

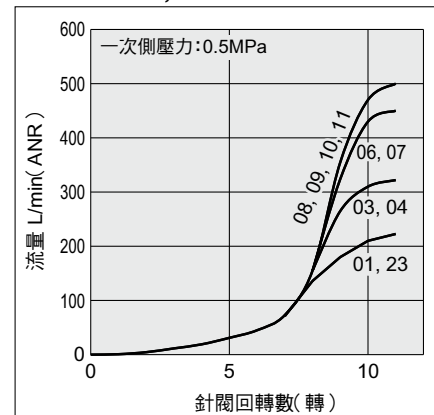

AS3201F, AS3211F
AS3301F, AS3311F

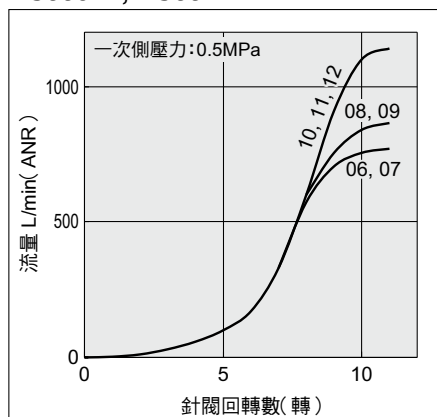

AS4201F, AS4211F
AS4301F, AS4311F

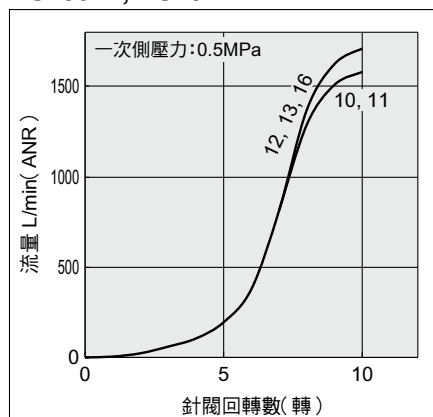

註) 圖內流量特性上的數字,所表示的為適用配管外徑的型號記號。

構造圖

L型

密封方式 / 墊片密封
螺牙的種類 / M5, 10-32UNF

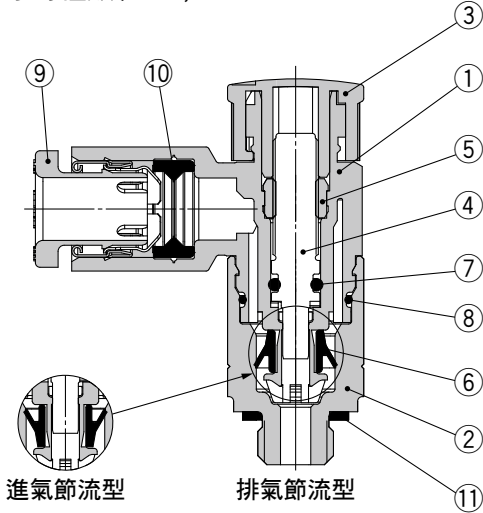

密封方式 / 密封劑
螺牙的種類 / R, NPT

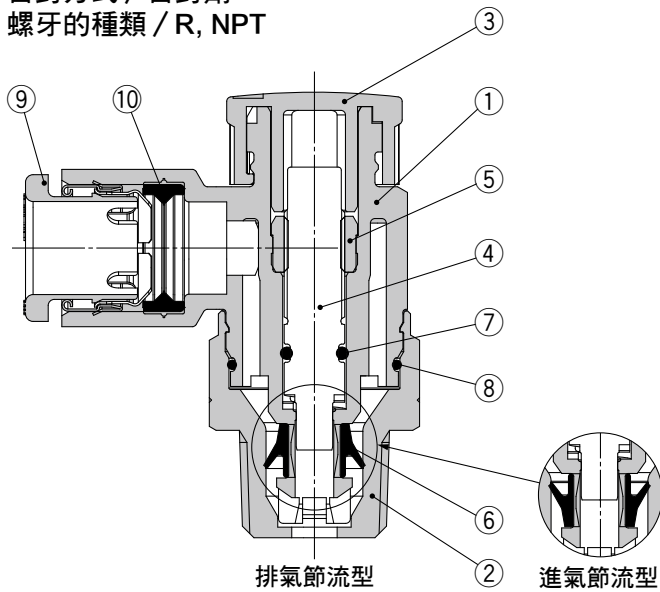

構成零件

編號	名稱	材質	備註
1	本體A	PBT	
2	本體B	黃銅	無電解鍍鎳
3	旋鈕	POM	
4	針閥	PBT	
5	針閥導軌	黃銅	無電解鍍鎳
6	U密封圈	HNBR	
7	O形環	NBR	
8	O形環	NBR	
9	墊片	-	
10	密封圈	NBR	
11	墊片	NBR 不鏽鋼	

萬向型

密封方式 / 墊片密封
螺牙的種類 / M5, 10-32UNF

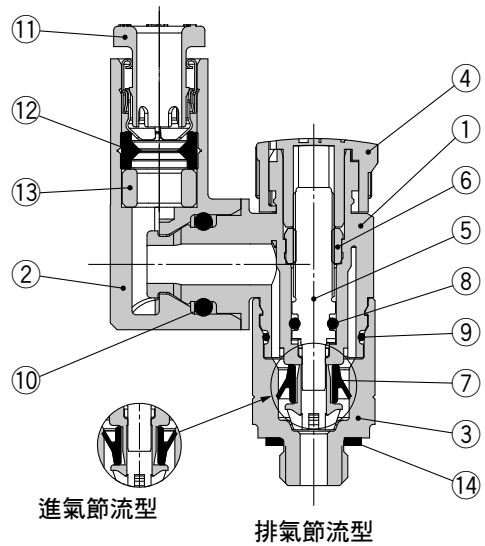

密封方式 / 密封劑
螺牙的種類 / R, NPT

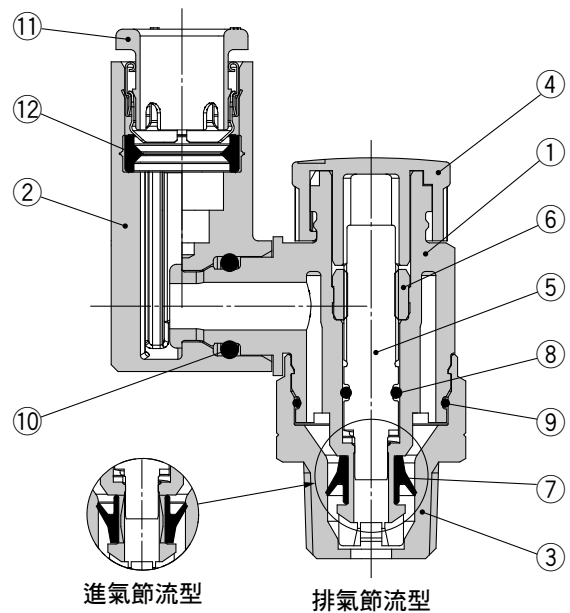

構成零件

編號	名稱	材質	備註
1	本體A	PBT	
2	L型本體	PBT	
3	本體B	黃銅	無電解鍍鎳
4	旋鈕	POM	
5	針閥	PBT	
6	針閥導軌	黃銅	無電解鍍鎳
7	U密封圈	HNBR	
8	O形環	NBR	
9	O形環	NBR	
10	O形環	NBR	
11	墊片	-	
12	密封圈	NBR	
13	連接塊	PBT(註)	
14	墊片	NBR 不鏽鋼	

註) 只限適用配管外徑 $\phi 3.2$, $\phi 1/8$ "裝置連接塊。

AS
密封劑 / 墊片

AS-FG
密封圈密封

Uni-AS
墊片密封

外形尺寸圖 / L型

密封方式 / 墊片密封

螺牙的種類 / M5, 10-32UNF

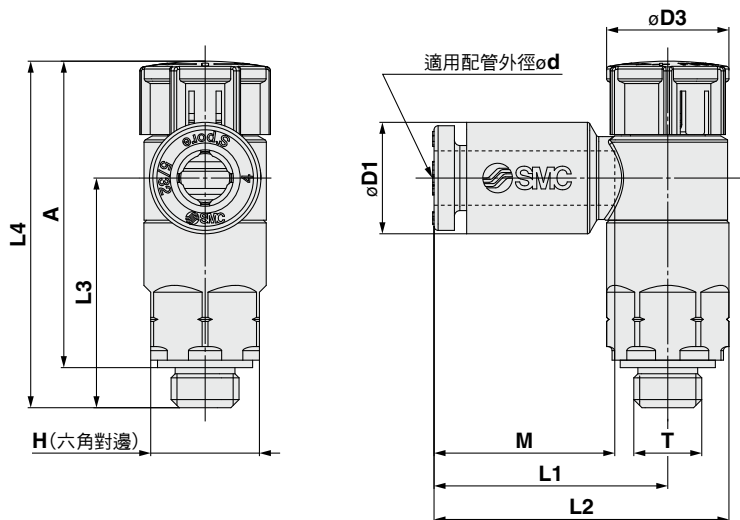

公釐尺寸

(mm)

型式	d	T	H	D1	D3	L1	L2	L3	L4 ^{註1)}		A ^{註2)}		M	質量 g	
									Unlock	Lock	Unlock	Lock			
AS12□1F-M5E-02A	2	M5×0.8 10/32UNF	8	5.8	9.4	15.8	20.3	16.9	26.5	25.4	23.5	22.4	11.9	5	
AS12□1F-U10/32E-02A				7.2		17.2	21.7								
AS12□1F-M5E-23A	3.2			8.2		18.6	23.1								16.5
AS12□1F-U10/32E-23A				10.4		18.6	23.1								16.5
AS12□1F-M5E-04A	4			10.4		18.6	23.1								16.5
AS12□1F-U10/32E-04A				10.4		18.6	23.1								16.5
AS12□1F-M5E-06A	6	10.4	18.6	23.1	16.5										
AS12□1F-U10/32E-06A		10.4	18.6	23.1	16.5										

註1) 參考尺寸

註2) 螺牙鎖入後的參考尺寸

英吋尺寸

(mm)

型式	d	T	H	D1	D3	L1	L2	L3	L4 ^{註1)}		A ^{註2)}		M	質量 g			
									Unlock	Lock	Unlock	Lock					
AS12□1F-M5E-01A	1/8"	M5×0.8 10/32UNF	8	7.2	9.4	17.2	21.7	16.9	26.5	25.4	23.5	22.4	13.3	5			
AS12□1F-U10/32E-01A				8.2											18.6	23.1	16.5
AS12□1F-M5E-03A	5/32"			11.2											18.6	23.1	16.5
AS12□1F-U10/32E-03A				11.2											18.6	23.1	16.5
AS12□1F-M5E-07A	1/4"			11.2											18.6	23.1	16.5
AS12□1F-U10/32E-07A				11.2											18.6	23.1	16.5

註1) 參考尺寸

註2) 螺牙鎖入後的參考尺寸

外形尺寸圖 / 萬向型

密封方式 / 墊片密封
螺牙的種類 / M5, 10-32UNF

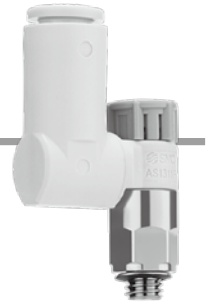
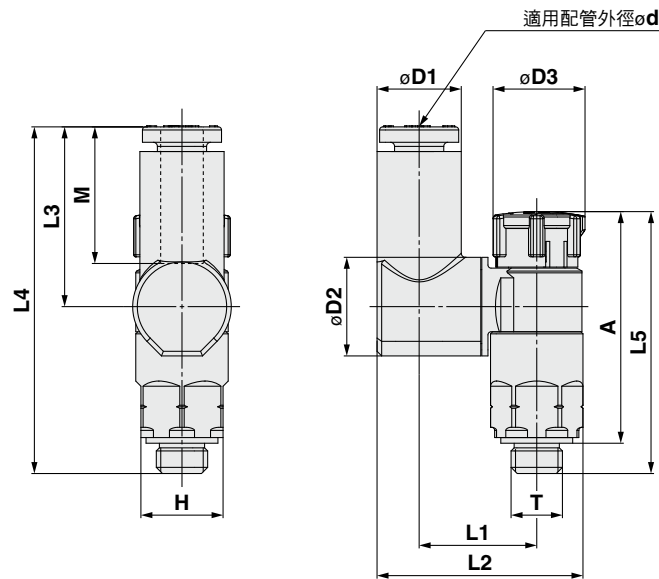

AS
密封劑 / 墊片

密封圈密封

Uni-AS
墊片密封

公釐尺寸

型式	d	T	H	D1	D2	D3	L1	L2	L3	L4	L5 ^{註1)}		A ^{註2)}		M	質量 g
											Unlock	Lock	Unlock	Lock		
AS13□1F-M5E-23A	3.2	M5×0.8 10/32UNF	8	7.2	9.6	9.4	11.6	19.4	17.5	33.8	26.5	25.4	23.5	22.4	13.3	6
AS13□1F-U10/32E-23A																
AS13□1F-M5E-04A	8.2															
AS13□1F-U10/32E-04A	11.5															
AS13□1F-M5E-06A	10.4															
AS13□1F-U10/32E-06A	6															

註1) 參考尺寸
註2) 螺牙鎖入後的參考尺寸

英吋尺寸

型式	d	T	H	D1	D2	D3	L1	L2	L3	L4	L5 ^{註1)}		A ^{註2)}		M	質量 g
											Unlock	Lock	Unlock	Lock		
AS13□1F-M5E-01A	1/8"	M5×0.8 10/32UNF	8	7.2	9.6	9.4	11.6	19.4	17.5	33.8	26.5	25.4	23.5	22.4	13.3	6
AS13□1F-U10/32E-01A																
AS13□1F-M5E-03A	8.2															
AS13□1F-U10/32E-03A	11.5															
AS13□1F-M5E-07A	11.2															
AS13□1F-U10/32E-07A	1/4"															

註1) 參考尺寸
註2) 螺牙鎖入後的參考尺寸

外形尺寸圖 / L型

密封方式 / 密封劑
螺牙的種類 / R, NPT

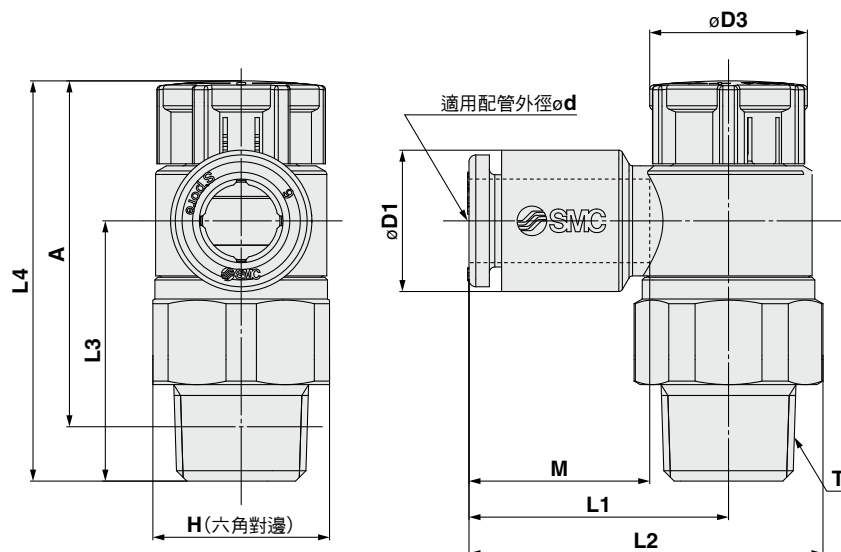

公釐尺寸

型式	d	T	H	D1	D3	L1	L2	L3	L4 ^{註1)}		A ^{註2)}		M	質量 g
									Unlock	Lock	Unlock	Lock		
AS22□1F-01-23(S)A	3.2	1/8	13 (12.7)	7.2	12	19.1	26.2	19.1	30.6	29.2	27.5	26.1	13.3	9(9)
AS22□1F-01-04(S)A	4			8.2										10(9)
AS22□1F-01-06(S)A	6			10.4										11(10)
AS22□1F-01-08(S)A	8			13.2										12(11)
AS22□1F-01-10(S)A	10	15.9	15.9	25.3	32.4									
AS22□1F-02-23(S)A	3.2	1/4	17 (17.5)	7.2	13	20.9	30.2(30.3)	22.6	36.6	35	31.1	29.5	13.3	18(19)
AS22□1F-02-04(S)A	4			8.2										19(20)
AS22□1F-02-06(S)A	6			10.4										20(21)
AS22□1F-02-08(S)A	8			13.2										21(22)
AS22□1F-02-10(S)A	10	15.9	26.9	36.2(36.3)	35.7									
AS32□1F-02-06(S)A	6	1/4	19	10.4	16.6	21.8	32.1	36.4	50	48.4	44.5	42.9	13.3	40(40)
AS32□1F-02-08(S)A	8			13.2										41(41)
AS32□1F-02-10(S)A	10			15.9										42(42)
AS32□1F-02-12(S)A	12			18.5										43(43)
AS32□1F-03-06(S)A	6	3/8	19	10.4	16.6	21.8	32.1	28.7	42.3	40.7	37.1	35.5	13.3	31(32)
AS32□1F-03-08(S)A	8			13.2										32(33)
AS32□1F-03-10(S)A	10			15.9										33(33)
AS32□1F-03-12(S)A	12			18.5										34(35)
AS42□1F-04-10(S)A	10	1/2	24 (23.8)	15.9	18.8	27.4	40.3(40.2)	36.2	50.8	49.2	43.7	42.1	15.6	54(53)
AS42□1F-04-12(S)A	12			18.5										55(55)
AS42□1F-04-14(S)A	14			21.2										56(56)
AS42□1F-04-16(S)A	16			23.8										60(59)

註1) 參考尺寸 註2) 螺牙鎖入後的參考尺寸 註3) () 內為NPT螺牙的尺寸

英寸尺寸

型式	d	T	H	D1	D3	L1	L2	L3	L4 ^{註1)}		A ^{註2)}		M	質量 g
									Unlock	Lock	Unlock	Lock		
AS22□1F-01-01(S)A	1/8"	1/8	13 (12.7)	7.2	12	19.1	26.2	19.1	30.6	29.2	27.5	26.1	13.3	9(9)
AS22□1F-01-03(S)A	5/32"			8.2										10(9)
AS22□1F-01-07(S)A	1/4"			11.2										11(10)
AS22□1F-01-09(S)A	5/16"			13.2										12(11)
AS22□1F-02-01(S)A	1/8"	1/4	17 (17.5)	7.2	13	20.9	30.2(30.3)	22.6	36.6	35	31.1	29.5	13.3	18(19)
AS22□1F-02-03(S)A	5/32"			8.2										19(19)
AS22□1F-02-07(S)A	1/4"			11.2										20(20)
AS22□1F-02-09(S)A	5/16"			13.2										21(21)
AS22□1F-02-11(S)A	3/8"	15.5	26.4	35.7(35.8)	35.7									
AS32□1F-02-07(S)A	1/4"	1/4	19	11.2	16.6	21.8	32.1	36.4	50	48.4	44.5	42.9	13.3	40(40)
AS32□1F-02-09(S)A	5/16"			13.2										41(41)
AS32□1F-02-11(S)A	3/8"			15.5										42(42)
AS32□1F-03-07(S)A	1/4"			11.2										43(43)
AS32□1F-03-09(S)A	5/16"	3/8	19	11.2	16.6	21.8	32.1	28.7	42.3	40.7	37.1	35.5	13.3	31(32)
AS32□1F-03-11(S)A	3/8"			13.2										32(33)
AS32□1F-03-13(S)A	7/16"			15.5										33(33)
AS32□1F-03-15(S)A	1/2"			18.5										34(35)
AS42□1F-04-11(S)A	3/8"	1/2	24 (23.8)	15.5	18.8	27.4	40.3(40.2)	36.2	50.8	49.2	43.7	42.1	15.6	54(53)
AS42□1F-04-13(S)A	1/2"			19.3										55(55)

註1) 參考尺寸 註2) 螺牙鎖入後的參考尺寸 註3) () 內為NPT螺牙的尺寸

外形尺寸圖 / 萬向型

密封方式 / 密封劑
螺牙的種類 / R, NPT

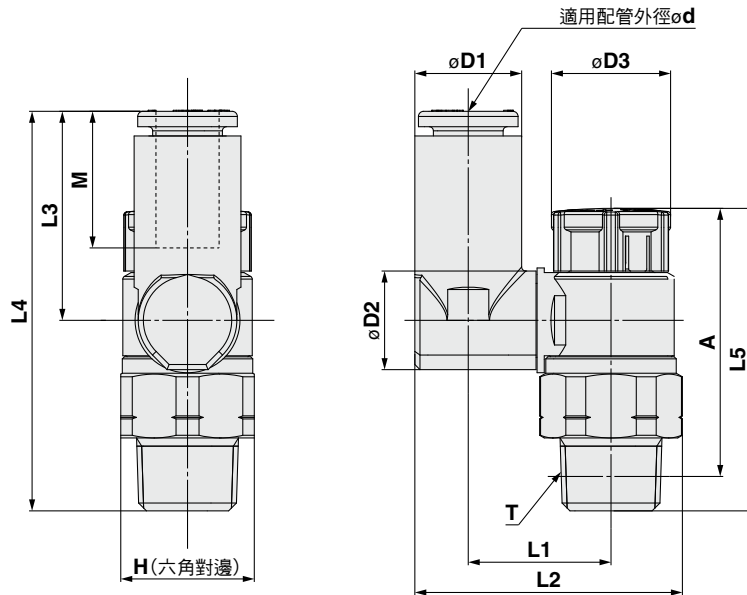

AS
密封劑 / 墊片
AS-FG

密封圈密封

Uni-AS
墊片密封

公釐尺寸

型式	d	T	H	D1	D2	D3	L1	L2	L3	L4	L5 ^{註1)}		A ^{註2)}		M	質量 g			
											Unlock	Lock	Unlock	Lock					
AS23□1F-01-23(S)A	3.2	1/8	13 (12.7)	7.2	9.6	12	13.3	24	17.5	36	30.6	29.2	27.5	26.1	13.3	10(10)			
AS23□1F-01-04(S)A	4			8.2			13.9	25.1								11(10)			
AS23□1F-01-06(S)A	6			10.4			16.4	26.2								12(12)			
AS23□1F-01-08(S)A	8			13.2			16.4	30.1								20.4	38.8	14.2	12(12)
AS23□1F-02-04(S)A	4	1/4	17 (17.5)	8.2	12.9	13	16.5	29.9(30)	17.5	40.1	36.6	35	31.1	29.5	13.3	19(20)			
AS23□1F-02-06(S)A	6			11.2			19	33.8(33.9)								21.4	43.9	21(22)	
AS23□1F-02-08(S)A	8			13.2			19	34.9(35)								23.5	46	22(22)	
AS23□1F-02-10(S)A	10			15.9			20.9	38.1(38.2)								24.7	47.3	15.6	23(24)
AS33□1F-02-06(S)A	6	1/4	19	11.2	12.9	16.6	20.2	36	21.4	57.8	50	48.4	44.5	42.9	13.3	42(42)			
AS33□1F-02-08(S)A	8			13.2			20.2	37.1								23.5	59.9	14.2	43(43)
AS33□1F-02-10(S)A	10			15.9			23	41.2								26.1	62.5	15.6	46(46)
AS33□1F-02-12(S)A	12			18.5			23	42.5								28.3	64.7	17	48(48)
AS33□1F-03-06(S)A	6	3/8	19	11.2	12.9	16.6	20.2	36	21.4	50.1	42.3	40.7	37.1	35.5	13.3	34(35)			
AS33□1F-03-08(S)A	8			13.2			20.2	37.1								23.5	52.2	14.2	35(36)
AS33□1F-03-10(S)A	10			15.9			23	41.2								26.1	54.8	15.6	38(39)
AS33□1F-03-12(S)A	12			18.5			23	42.5								28.3	57	17	40(41)
AS43□1F-04-10(S)A	10	1/2	24 (23.8)	15.9	17.4	18.8	25.6	46.4(46.3)	26.1	61.2	50.8	49.2	43.7	42.1	15.6	61(59)			
AS43□1F-04-12(S)A	12			18.5			26.2	48.3(48.2)								28.3	63.4	17	64(63)

註1) 參考尺寸 註2) 螺牙鎖入後的參考尺寸 註3) ()內為NPT螺牙的尺寸

英吋尺寸

型式	d	T	H	D1	D2	D3	L1	L2	L3	L4	L5 ^{註1)}		A ^{註2)}		M	質量 g											
											Unlock	Lock	Unlock	Lock													
AS23□1F-01-01(S)A	1/8"	1/8	13 (12.7)	7.2	9.6	12	13.3	24	17.5	36	30.6	29.2	27.5	26.1	13.3	10(10)											
AS23□1F-01-03(S)A	5/32"			8.2			13.9	25.1								11(10)											
AS23□1F-01-07(S)A	1/4"			11.2			16.4	29.1								20.2	38.7	14.2	12(12)								
AS23□1F-01-09(S)A	5/16"			13.2			16.4	30.1								21.5	40	14.2	12(12)								
AS23□1F-02-03(S)A	5/32"	1/4	17 (17.5)	8.2	12.9	13	16.5	29.9(30)	17.5	40.1	36.6	35	31.1	29.5	13.3	19(20)											
AS23□1F-02-07(S)A	1/4"			11.2			19	33.8(33.9)								21.4	43.9	21(22)									
AS23□1F-02-09(S)A	5/16"			13.2			19	34.9(35)								23.5	46	22(22)									
AS23□1F-02-11(S)A	3/8"			15.9			20.9	38.1(38.2)								24.7	47.3	15.6	23(24)								
AS33□1F-02-07(S)A	1/4"	3/8	19	11.2	12.9	16.6	20.2	36	21.4	57.8	50	48.4	44.5	42.9	13.3	42(42)											
AS33□1F-02-09(S)A	5/16"			13.2			20.2	37.1								23.5	59.9	14.2	43(43)								
AS33□1F-02-11(S)A	3/8"			15.9			23	41.2								26.1	62.5	15.6	46(46)								
AS33□1F-03-07(S)A	1/4"			11.2			23	36								21.4	50.1	13.3	34(35)								
AS33□1F-03-09(S)A	5/16"	3/8	19	13.2	12.9	16.6	20.2	37.1	23.5	52.2	42.3	40.7	37.1	35.5	14.2	35(36)											
AS33□1F-03-11(S)A	3/8"			15.9			23	41.2								26.1	54.8	15.6	38(39)								
AS43□1F-04-11(S)A	3/8"			1/2			24 (23.8)	15.9								17.4	18.8	25.6	46.4(46.3)	26.1	61.2	50.8	49.2	43.7	42.1	15.6	61(59)
AS43□1F-04-13(S)A	1/2"							18.5										26.2	48.3(48.2)								28.3

註1) 參考尺寸 註2) 螺牙鎖入後的參考尺寸 註3) ()內為NPT螺牙的尺寸

AS Series 訂製品規格

關於詳細尺寸、規格及交期，請與本公司確認。



1 潤滑劑：凡士林

-X12



(例)AS2201F-01-04SA-X12

鐳射印字

2 無潤滑脂(密封材鍍氟素)+節流閥(無逆止閥)

-X21

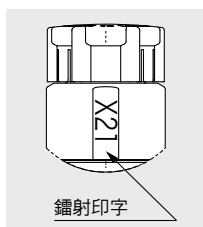

(例)AS2201F-01-04SA-X21

註1)不是無發塵。
註2)節流閥只對應排氣節流的型號。
註3)只有針閥O形環部為鍍氟素。

鐳射印字

3 節流閥(無逆止閥)

-X214

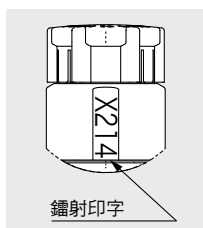

(例)AS2201F-01-04SA-X214

註)節流閥只對應排氣節流的型號。

鐳射印字

4 無塵室

10-

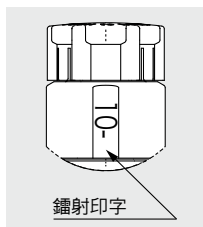

(例)10-AS2201F-01-04SA

註1)使用潤滑脂為氟素系潤滑脂。
註2)發塵量的等級為等級3。
註3)螺牙的種類 / G除外。

鐳射印字