

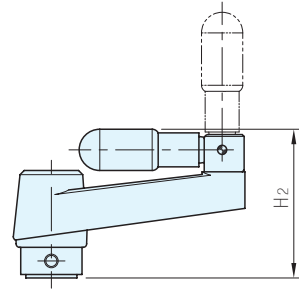

MT-AT-□0-M  
附旋轉握把

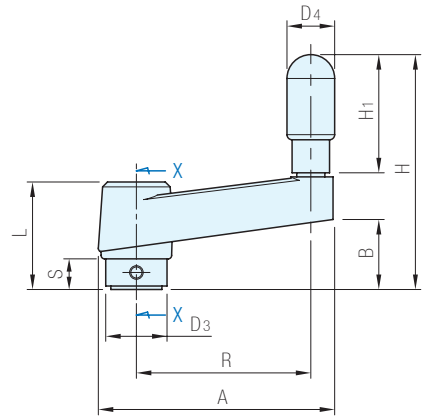

MT-AT-□1-M  
附可折疊旋轉握把

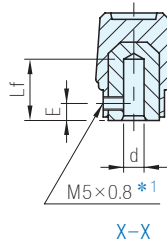

曲柄	嵌件	握把
聚醯胺 (強化玻璃纖維) 霧光黑	SUM22L 四氧化三鐵膜	聚醯胺 霧光黑

品號	R	d (H9)	Lf	A	H	H <sub>2</sub>	D <sub>3</sub>	L	S	E	B	D <sub>4</sub>	H <sub>1</sub>	重量 (g)	備註
MT-AT-020-M	64	8	20	86	78	-	20	31.5	9	5	17.5	15.5	45	82	附旋轉握把
MT-AT-030-M	80	10	25	106	99		24	37	11	6	23.5	18	60	118	
MT-AT-040-M	100	12	24	128	106	20	31.5	9	5	17.5	15.5	45	89		
MT-AT-021-M	64	8	20	86	91	47	24	31.5	9	5	17.5	15.5	45	89	附可折疊 旋轉握把
MT-AT-031-M	80	10	25	106	111	53.5		37	11	6	23.5	18	60	130	
MT-AT-041-M	100	12	24	128	124	59.5		40.5	10	5	25	22	65	200	

**Wa. 注意**

\*1 本產品為追加螺絲孔加工

訂貨：  交期：

MT-AT-020-M

**Ex. 使用例**

