

RoHS

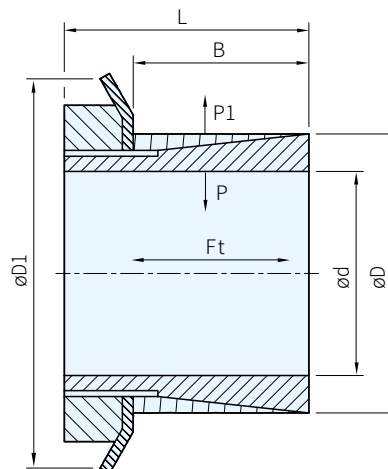

材質

S45C

品號	庫存	d	D	D1	L	B	軸向推力 Ft(KN)	傳達扭矩 Mt(Nm)	軸面壓力 P(N/mm <sup>2</sup> )	鞍面壓力 P1(N/mm <sup>2</sup> )	12.9級螺絲		鎖緊扭矩 Ts(Nm)	
											數量	規格		
SI-15	△	15	25	32	30	20	9	77	91	55	1	M20×1	95	
SI-18	△	18	30	38	32		13	125	98	59		M25×1.5	160	
SI-19	△	19						132	93					
SI-20	△	20						139	88					
SI-24	△	24	35	45	36	25	15	202	74	51	M30×1.5	220		
SI-25	△	25					210	71						
SI-28	△	28	40	52	42	30	20	312	76	53	M35×1.5	340		
SI-30	△	30					335	71						
SI-35	△	35	45	58	44		25	483	75	58			M40×1.5	480
SI-40	△	40	50	65	45		31	696	82	66			M45×1.5	680
SI-45	△	45	55	70	46	36	902	84	69	M50×1.5	870			
SI-50	△	50	60	75		37	1014	77	64	M55×2	970			
SI-55	△	55	65	80		38	1158	73	61	M60×2	1100			
SI-60	△	60	70	85		41	1379		62	M65×2	1300			

訂貨：品號 交期：14 天

SI-15