

RoHS

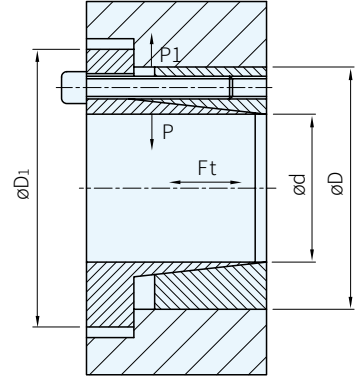
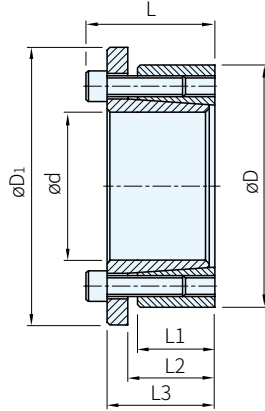

材質
S45C

品號	庫存	d	D	D1	L1	L2	L3	L	軸向推力 Ft(KN)	傳達扭矩 Mt(Nm)	軸面壓力 P(N/mm ²)	鞍面壓力 P1(N/mm ²)	12.9級螺絲		鎖緊扭矩 Ts(Nm)		
													數量	規格			
SES-19	△	19								243	234						
SES-20	△	20	47	56					26	256	222	94	5	M6×20	17		
SES-22	△	22								282	202						
SES-24	△	24	50	59						368	222	106	6				
SES-25	△	25								383	213						
SES-28	△	28	55	64	17	22	28	34	31	429	190	97	8				
SES-30	△	30								460	177						
SES-32	△	32	60	69						655	222	118	8				
SES-35	△	35								716	203						
SES-38	△	38	65	74					41	778	187	109	8				
SES-40	△	40								819	178						
SES-42	△	42	75	84						1361	227	127	7	M8×25	41		
SES-45	△	45								1458	212						
SES-50	△	50	80	89						1620	191	119	8				
SES-55	△	55	85	91	20	25	33	41		2037	199	129	8				
SES-60	△	60	90	99						2223	182	121	9				
SES-65	△	65	95	104						83	2710	189	126	9			
SES-70	△	70	110	119							4203	211	134	8	M10×30	83	
SES-75	△	75	115	124							4754	197	128	8			
SES-80	△	80	120	129	24	30	40	50			4804	184	123	9			
SES-85	△	85	125	134							5742	195	133	10			
SES-90	△	90	130	139							6080	184	128	10			
SES-95	△	95	135	144								137		8	M12×35	145	
SES-100	△	100	145	154							8732	198		8			
SES-110	△	110	155	164	26	32	44	56			9605	180	128	9			
SES-120	△	120	165	174							11787	186	135	12	M14×40	230	
SES-130	△	130	180	189							17024	175	126	12			
SES-140	△	140	190	199	34	40	54	64			267	18703	166	122			9
SES-150	△	150	200	209							297	22259	172	129			10
SES-160	△	160	210	219							326	26119	177	135			11
SES-170	△	170	225	234								106		12	M14×40	230	
SES-180	△	180	235	244							30276	140	102	12			
SES-190	△	190	250	259	44	50	64	78			32057	133	119	15			
SES-200	△	200	265	269							42302	157	119	15			
											44528	149	115				

備註

- 普遍使用
- 自動校對

訂貨： 品號 交期： 14 天

SES-19