

MSLP-* $\phi 32$ 容許阻擋能力表

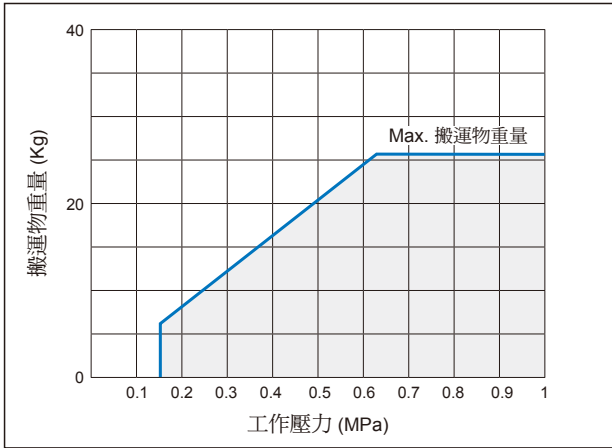

MSLL $\phi 25, \phi 40$ 容許阻擋能力表

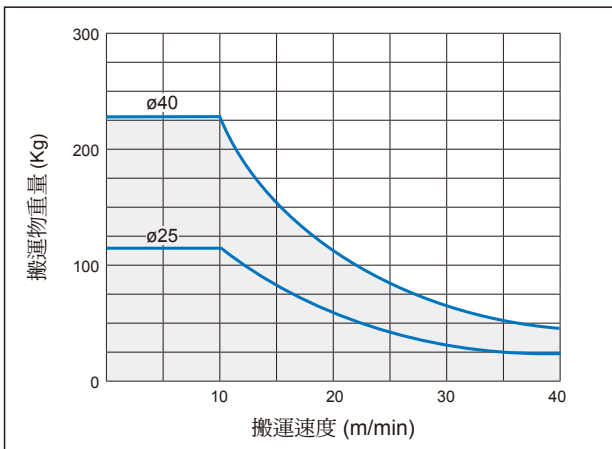

MSLL $\phi 25, \phi 40$ 常用橫荷重表

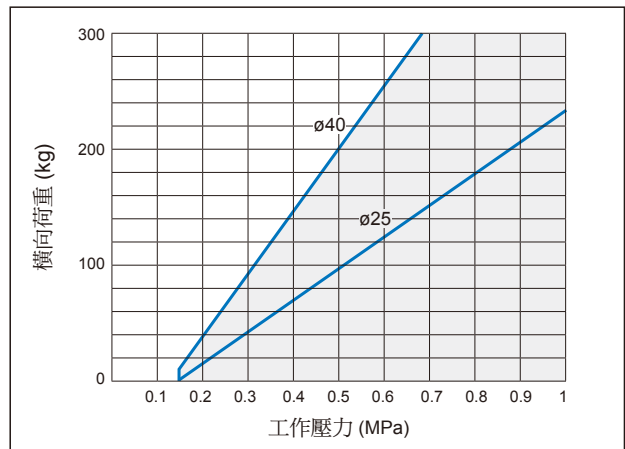

MSLD $\phi 50$ 容許阻擋能力表

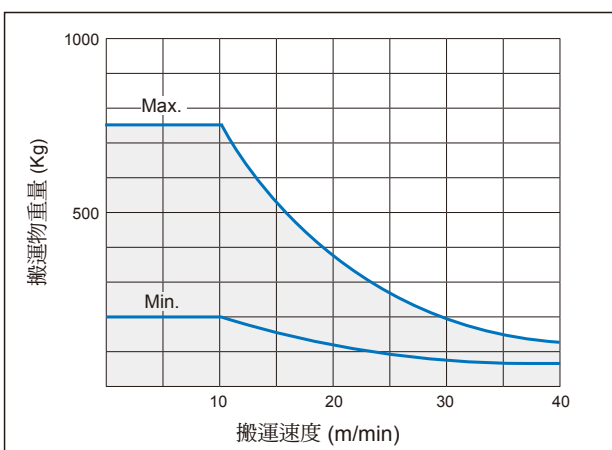

MSLD $\phi 50$ 常用橫荷重表

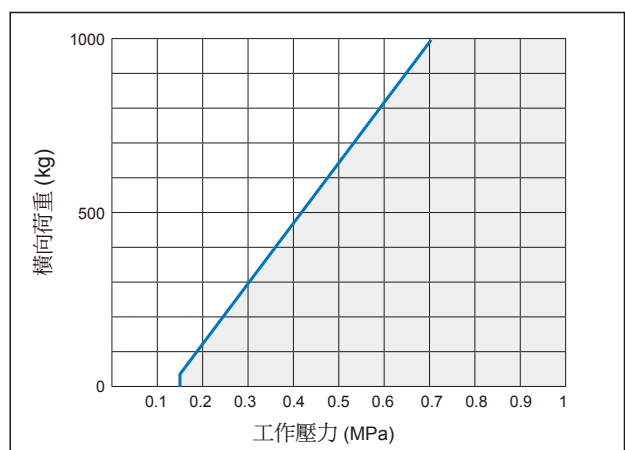

MSLD 外觀尺寸 $\phi 50$

阻擋氣壓缸



MSLD $\phi 50-50$

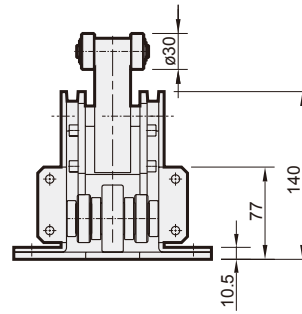
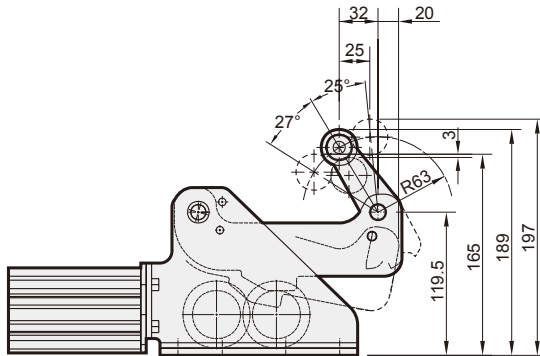
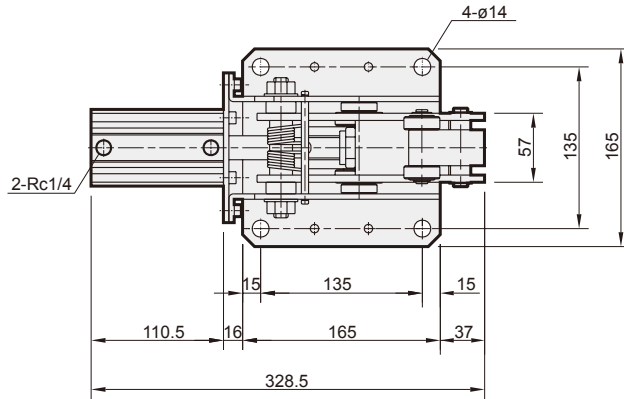

配管參考

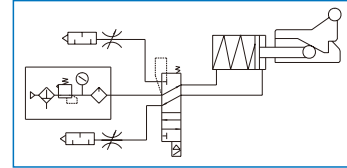

* 滾輪為不銹鋼材質