

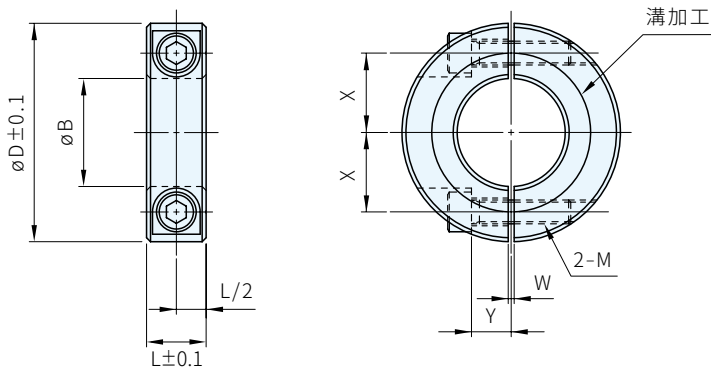

材質	處理	附屬品
S45C	染黑	六角螺栓(染黑)2支
SUS304	-	六角螺栓(SUS×M7)2支



øB寸法公差

øB	公差
ø10.5~42.7	+0.05 +0.01
ø48.6	+0.06 +0.01

S45C		SUS304		適用鋼管稱呼		B	L	D	W	X	Y	M
品號	庫存	品號	庫存	(A)	(B)							
SCSS06A15C	△	SCSS06A15S	△	6	1/8	10.5	15	35	1.5	10	6	M6×18
SCSS08A15C	△	SCSS08A15S	△	8	1/4	13.8	15	40	1.5	13	8	M6×18
SCSS10A15C	△	SCSS10A15S	△	10	3/8	17.3	15	45	1.5	15	8	M6×20
SCSS15A15C	△	SCSS15A15S	△	15	1/2	21.7	15	50	1.5	18	10	M6×20
SCSS20A15C	△	SCSS20A15S	△	20	3/4	27.2	15	55	1.5	20	10	M6×25
SCSS25A15C	△	SCSS25A15S	△	25	1	34	15	60	2	23	12	M6×25
SCSS32A18C	△	SCSS32A18S	△	32	1 1/4	42.7	18	75	3	28	14	M8×30
SCSS40A22C	△	SCSS40A22S	△	40	1 1/2	48.6	22	85	3	32	16	M10×35

訂貨：  交期：  天  
SCSS06A15C