

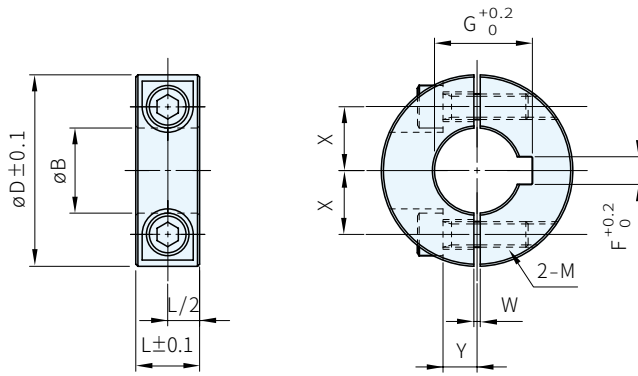

材質	處理	附屬品
S45C	染黑	六角螺栓(染黑)2支
SUS304	-	六角螺栓(SUS×M7)2支



φB寸法公差

φB	公差
φ15~45	+0.05 +0.01
φ50	+0.06 +0.01

S45C		SUS304		B	L	D	鍵槽		W	X	Y	M
品號	庫存	品號	庫存				F	G				
SCSS1515CK	△	SCSS1515SK	△	15	15	40	5.5	17.5	1.5	13	8	M6×20
SCSS1615CK	△	SCSS1615SK	△	16	15	40	5.5	18.5	1.5	13	8	M6×20
SCSS2015CK	△	SCSS2015SK	△	20	15	45	6.5	23	1.5	15	8	M6×20
SCSS2515CK	△	SCSS2515SK	△	25	15	50	8.5	28.5	1.5	18	10	M6×25
SCSS3015CK	△	SCSS3015SK	△	30	15	55	8.5	33.5	1.5	20	10	M6×25
SCSS3515CK	△	SCSS3515SK	△	35	15	60	10.5	38.8	2	23	12	M6×25
SCSS4018CK	△	SCSS4018SK	△	40	18	70	12.5	43.8	2	26	13	M8×30
SCSS4518CK	△	SCSS4518SK	△	45	18	75	14.5	49	3	28	14	M8×30
SCSS5022CK	△	SCSS5022SK	△	50	22	85	14.5	54	3	32	16	M10×35

**PS** 備註

・上記以外の尺寸，請參考追加加工頁數

訂貨：  交期：  天

SCSS1515CK