

RoHS SUS

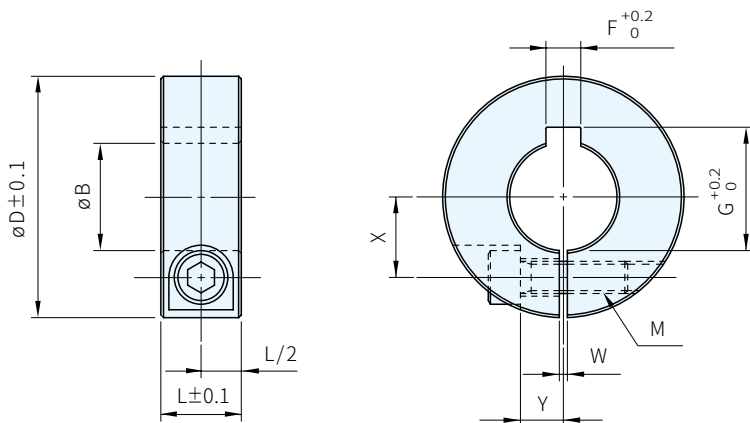

材質	處理	附屬品
S45C	染黑	六角螺栓(染黑)1支
SUS304	-	六角螺栓(SUS×M7)1支



øB寸法公差

øB	公差
ø15~45	+0.05 +0.01
ø48~50	+0.06 +0.01

S45C		SUS304		B	L	D	鍵槽		W	X	Y	M
品號	庫存	品號	庫存				F	G				
SCS1515CK	△	SCS1515SK	△	15	15	40	5.5	17.5	1.5	13	8	M6×20
SCS1615CK	△	SCS1615SK	△	16	15	40	5.5	18.5	1.5	13	8	M6×20
SCS1815CK	△	-		18	15	45	6.5	21	1.5	15	8	M6×20
SCS1915CK	△	-		19	15	45	6.5	22	1.5	15	8	M6×20
SCS2015CK	△	SCS2015SK	△	20	15	45	6.5	23	1.5	15	8	M6×20
SCS2215CK	△	-		22	15	50	8.5	25.5	1.5	18	10	M6×25
SCS2415CK	△	-		24	15	50	8.5	27.5	1.5	18	10	M6×25
SCS2515CK	△	SCS2515SK	△	25	15	50	8.5	28.5	1.5	18	10	M6×25
SCS2815CK	△	-		28	15	55	8.5	31.5	1.5	20	10	M6×25
SCS3015CK	△	SCS3015SK	△	30	15	55	8.5	33.5	1.5	20	10	M6×25
SCS3215CK	△	-		32	15	60	10.5	35.8	2	23	12	M6×25
SCS3515CK	△	SCS3515SK	△	35	15	60	10.5	38.8	2	23	12	M6×25
SCS3818CK	△	-		38	18	70	10.5	41.8	2	26	13	M8×30
SCS4018CK	△	SCS4018SK	△	40	18	70	12.5	43.8	2	26	13	M8×30
SCS4218CK	△	-		42	18	75	12.5	45.8	3	28	14	M8×30
SCS4518CK	△	SCS4518SK	△	45	18	75	14.5	49	3	28	14	M8×30
SCS4822CK	△	-		48	22	85	14.5	52	3	32	16	M10×35
SCS5022CK	△	SCS5022SK	△	50	22	85	14.5	54	3	32	16	M10×35

PS 備註

· 上記以外の尺寸，請參考追加加工頁數

訂貨： 交期： 天

SCS1515CK