

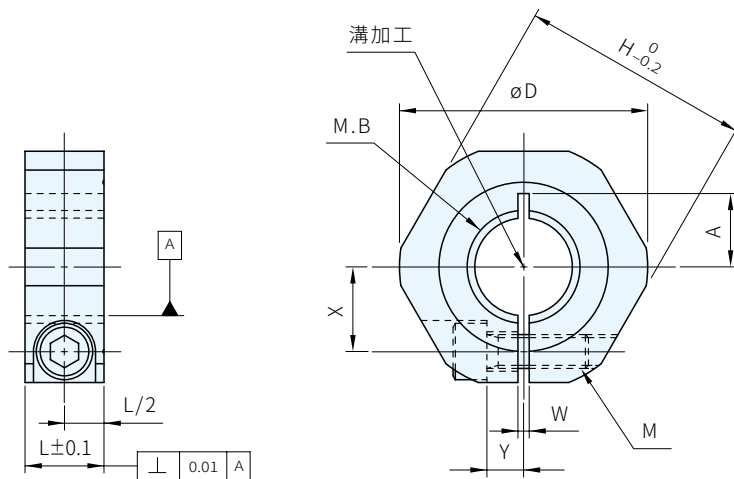

材質	處理	附屬品
SGD3	染黑	六角螺栓(染黑)1支
SUS303	-	六角螺栓(SUS×M7)1支



SGD3		SUS303		內徑螺紋 M.B	L	H	D	W	X	Y	A	M
品號	庫存	品號	庫存									
SCS08H09CH	△	-		M8×0.75	9	24	26	1.5	7	4	7	M4×10
-		SCS08H09SH	△	M8×0.75	9	24	26	1.5	7	4	8.5	M4×10
SCS10H09CH	△	-		M10×0.75	9	27	29	1.5	9	4	8	M4×10
-		SCS10H09SH	△	M10×0.75	9	27	29	1.5	9	4	10	M4×10
SCS12H12CH	△	-		M12×1	12	30	32	1.5	9.5	4.5	9	M5×14
-		SCS12H12SH	△	M12×1	12	30	32	1.5	9.5	4.5	11	M5×14
SCS15H14CH	△	-		M15×1	14	36	39	2	12.5	5	10.5	M6×15
-		SCS15H14SH	△	M15×1	14	36	39	2	12.5	5	12	M6×15
SCS16H14CH	△	-		M16×1	14	36	39	2	12.5	5	10.5	M6×15
-		SCS16H14SH	△	M16×1	14	36	39	2	12.5	5	12	M6×15
SCS20H14CH	△	-		M20×1	14	41	44	2	15	6.5	13	M6×18
-		SCS20H14SH	△	M20×1	14	41	44	2	15	6.5	15	M6×18
SCS25H14CH	△	SCS25H14SH	△	M25×1.5	14	46	50	2	17	7.5	15	M6×20
SCS30H14CH	△	SCS30H14SH	△	M30×1.5	14	50	54	2	19.5	8.5	18	M6×20
SCS35H14CH	△	SCS35H14SH	△	M35×1.5	14	55	60	2	22	10	20	M6×25

訂貨： 交期： 天

SCS08H09CH