

RoHS

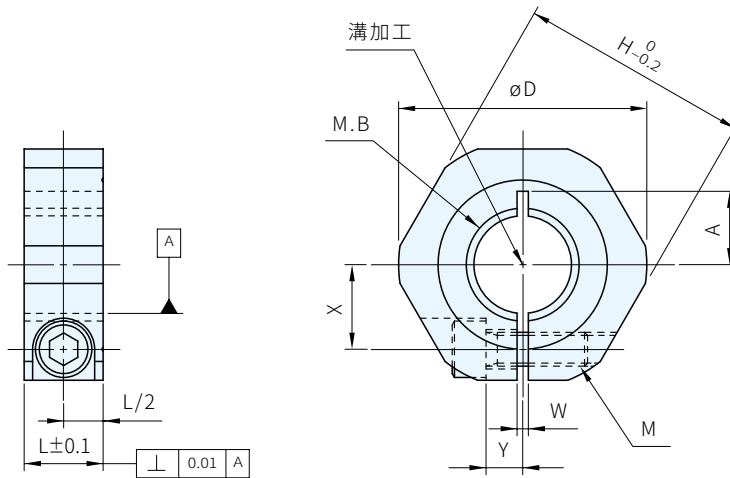

材質	處理	附屬品
SGD3	染黑	六角螺絲(染黑)1支



品號	庫存	內徑螺紋 M.B	L	H	D	W	X	Y	A	M
SCS08N09CH	△	M8×1.25	9	24	26	1.5	7	4	7	M4×10
SCS10N09CH	△	M10×1.5	9	27	29	1.5	9	4	8	M4×10
SCS12N12CH	△	M12×1.75	12	30	32	1.5	9.5	4.5	9	M5×14
SCS16N14CH	△	M16×2	14	36	39	2	12.5	5	10.5	M6×15
SCS20N14CH	△	M20×2.5	14	41	44	2	15	6.5	13	M6×18
SCS24N14CH	△	M24×3	14	46	50	2	17	7.5	15	M6×20
SCS30N14CH	△	M30×3.5	14	50	54	2	19.5	8.5	18	M6×20

 訂貨：  交期：  天

SCS08N09CH