

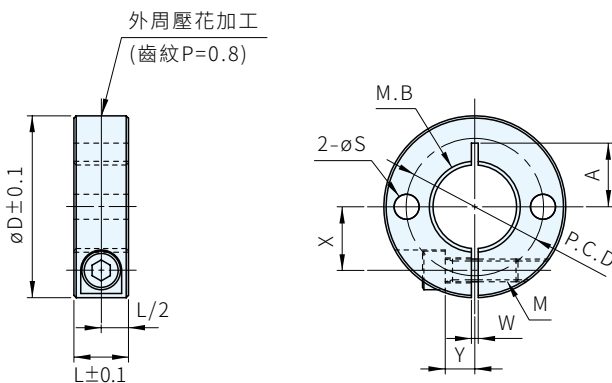

材質	處理	附屬品
S45C	染黑	六角螺栓(染黑)1支



品 號	庫 存	內徑螺紋 M.B	L	D	橫孔		W	X	Y	A	M
					S	P.C.D					
SCS08CA10C	△	M8×1	10	23	3.5	15	1.5	7	4	8.5	M3×10
SCS08CB10C	△	M8×1.25	10	23	3.5	15	1.5	7	4	8.5	M3×10
SCS10C10C	△	M10×1.25	10	25	3.5	18	1.5	8	5	9.5	M3×10
SCS12CA10C	△	M12×1.25	10	27	3.5	19	1.5	9	5	9.5	M4×12
SCS12CB10C	△	M12×1.5	10	27	3.5	19	1.5	9	5	9.5	M4×12
SCS14C10C	△	M14×1.5	10	29	3.5	21	1.5	10	5	10.5	M4×12
SCS16C10C	△	M16×1.5	10	32	4.5	24	1.5	11.5	5	11	M4×12
SCS18C11C	△	M18×1.5	11	34	4.5	26	1.5	12.5	6	12	M4×12
SCS20C12C	△	M20×1.5	12	40	5.5	30	1.5	14	6.5	14	M5×16
SCS22C13C	△	M22×1.5	13	42	5.5	32	1.5	15	7	15	M5×16
SCS26C14C	△	M26×1.5	14	46	5.5	36	1.5	17	7.5	17	M5×16
SCS27CA14C	△	M27×1.5	14	47	5.5	37	1.5	17.5	7.5	17.5	M5×16
SCS27CB14C	△	M27×2	14	47	5.5	37	1.5	17.5	7.5	17.5	M5×16
SCS30C15C	△	M30×1.5	15	52	6.6	41	1.5	19.5	8	19.5	M6×20

訂貨： 交期： 天
SCS08CA10C