

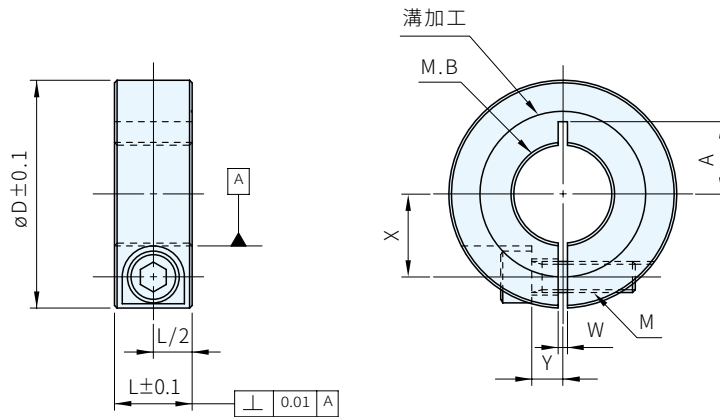

材質	處理	附屬品
S45C	染黑	六角螺栓(染黑)1支



品號	庫存	內徑螺紋 M.B	L	D	W	X	Y	A	M
SCS06H09C	△	M6×0.75	9	20	1.8	6	3	7	M3×10
SCS08H09C	△	M8×0.75	9	25	1.8	8.25	3	7.5	M3×10
SCS10H09C	△	M10×0.75	9	25	1.8	8.25	3	7.5	M3×10
SCS12H12C	△	M12×1	12	31	1.8	10.75	4	9.5	M4×12
SCS15H14C	△	M15×1	14	38	1.8	13.25	5	13.5	M5×16
SCS16H14C	△	M16×1	14	38	1.8	13.5	5	13.5	M5×16
SCS20H15C	△	M20×1	15	44	1.8	16	6	14	M6×20
SCS25H15C	△	M25×1.5	15	50	1.8	18.75	6	16.7	M6×20
SCS30H15C	△	M30×1.5	15	56	1.8	21.5	6	19.3	M6×20
SCS35H15C	△	M35×1.5	15	60	1.8	23.75	6	21.7	M6×20

訂貨：  交期：  天

SCS06H09C