

RoHS SUS

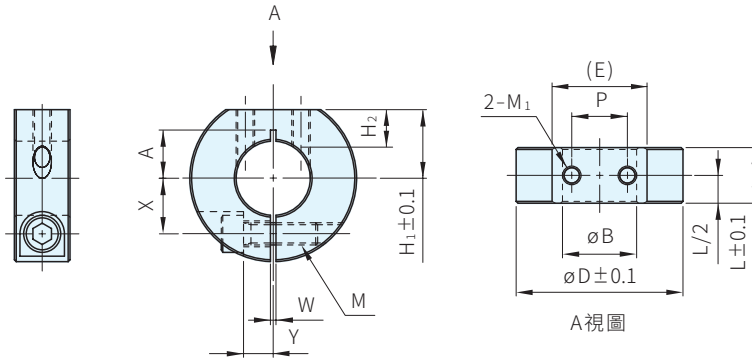

材質	處理	附屬品
S45C	染黑	六角螺柱(染黑)1支
S45C	無電解鍍	六角螺柱(SUS)1支
SUS304	-	六角螺柱(SUS)1支



øB寸法公差

øB	公差
ø8~45	+0.05 +0.01
ø50	+0.06 +0.01

S45C				SUS304			B	L	D	D切面				W	X	Y	A	M
染黑		無電解鍍		品號	庫存	H ₁				(E)	M ₁	P	H ₂					
品號	庫存	品號	庫存															
SCS0815CTN	△	SCS0815MTN	△	SCS0815STN	△	8	15	30	13	15	☆M3	8	7	1.5	10	6	8	M5×16
SCS1015CTN	△	SCS1015MTN	△	SCS1015STN	△	10	15	35	15	18	☆M4	10	7	1.5	11.5	6	10	M5×16
SCS1215CTN	△	SCS1215MTN	△	SCS1215STN	△	12	15	35	15	18	☆M4	10	7	1.5	11.5	6	10	M5×16
SCS1315CTN	△	SCS1315MTN	△	SCS1315STN	△	13	15	35	15	18	☆M4	10	7	1.5	11.5	6	10	M5×16
SCS1515CTN	△	SCS1515MTN	△	SCS1515STN	△	15	15	40	17	21.1	☆M5	12	7	1.5	13	8	-	M6×20
SCS1615CTN	△	SCS1615MTN	△	SCS1615STN	△	16	15	40	17	21.1	☆M5	12	7	1.5	13	8	-	M6×20
SCS1715CTN	△	SCS1715MTN	△	SCS1715STN	△	17	15	40	17	21.1	☆M5	12	7	1.5	13	8	-	M6×20
SCS1815CTN	△	SCS1815MTN	△	SCS1815STN	△	18	15	45	18.5	25.6	☆M5	15	7	1.5	15	8	-	M6×20
SCS2015CTN	△	SCS2015MTN	△	SCS2015STN	△	20	15	45	18.5	25.6	M5	15	9	1.5	15	8	-	M6×20
SCS2515CTN	△	SCS2515MTN	△	SCS2515STN	△	25	15	50	21	27.1	M5	20	10	1.5	18	10	-	M6×25
SCS3015CTN	△	SCS3015MTN	△	SCS3015STN	△	30	15	55	23.5	28.6	M6	21	10	1.5	20	10	-	M6×25
SCS3515CTN	△	SCS3515MTN	△	SCS3515STN	△	35	15	60	26	29.9	M6	23	10	2	23	12	-	M6×25
SCS4018CTN	△	SCS4018MTN	△	SCS4018STN	△	40	18	70	30	36.1	M6	26	12	2	26	13	-	M8×30
SCS4518CTN	△	SCS4518MTN	△	SCS4518STN	△	45	18	75	32.5	37.4	M6	28	12	3	28	14	-	M8×30
SCS5022CTN	△	SCS5022MTN	△	SCS5022STN	△	50	22	85	37	41.8	M8	28	13	3	32	16	-	M10×35

PS. 備註

- ☆印の螺紋孔無貫穿，但鑽孔是貫穿
- 上記以外の尺寸，請參考追加加工頁數

訂貨： 交期： 天

SCS0815CTN