

RoHS SUS

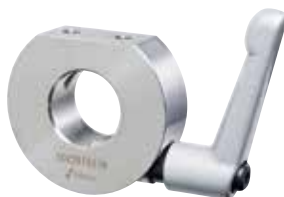

本體		把手	
材質	處理	材質	顏色
S45C	染黑	鋅合金	銀灰·橘
SUS304	-	鋅合金	銀灰·橘

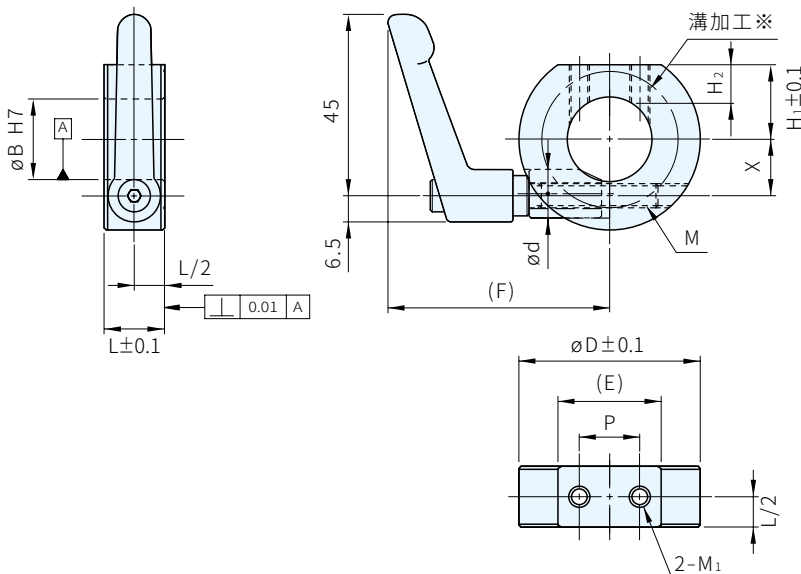

· 端面有溝側和對象物安裝在一起

S45C			SUS304			B	L	D	D切面				d	X	(F)	M			
品號	把手顏色	庫存	品號	把手顏色	庫存				H ₁	(E)	M ₁	P					H ₂		
SCK1015CTNS	銀灰	△	SCK1015STNS	銀灰	△	10	15	35	15	18	M4	10	7	12.1	9.5	49.8	M6×25		
SCK1215CTNS		△	SCK1215STNS		△	12	15	38	15	23.3	M4	10	7	12.1	10.5	50	M6×25		
SCK1515CTNS		△	SCK1515STNS		△	15	15	40	17	21.1	M5	12	7	12.1	12	53.4	M6×32		
SCK1615CTNS		△	SCK1615STNS		△	16	15	42	17	24.7	M5	12	7	12.1	12	54.5	M6×32		
SCK2015CTNS		△	SCK2015STNS		△	20	15	46	18.5	27.3	M5	15	10	12.1	14	55	M6×32		
SCK2515CTNS		△	SCK2515STNS		△	25	15	50	21	27.1	M5	20	11	12.1	16.5	55.6	M6×32		
SCK3015CTNS		△	SCK3015STNS		△	30	15	56	23.5	30.5	M6	21	10.5	12.1	19	59.1	M6×40		
SCK3520CTNS		△	SCK3520STNS		△	35	20	65	26	39	M6	23	10.7	14.1	22.5	60.7	M6×40		
SCK4020CTNS		△	SCK4020STNS		△	40	20	70	30	36.1	M6	26	12.6	14.1	25	65.4	M6×50		
SCK5020CTNS		△	SCK5020STNS		△	50	20	85	37	41.8	M6	28	14.5	14.1	29.5	72.7	M6×50		
SCK1015CTNO		橘	△		SCK1015STNO	橘	△	10	15	35	15	18	M4	10	7	12.1	9.5	49.8	M6×25
SCK1215CTNO			△		SCK1215STNO		△	12	15	38	15	23.3	M4	10	7	12.1	10.5	50	M6×25
SCK1515CTNO	△		SCK1515STNO	△	15		15	40	17	21.1	M5	12	7	12.1	12	53.4	M6×32		
SCK1615CTNO	△		SCK1615STNO	△	16		15	42	17	24.7	M5	12	7	12.1	12	54.5	M6×32		
SCK2015CTNO	△		SCK2015STNO	△	20		15	46	18.5	27.3	M5	15	10	12.1	14	55	M6×32		
SCK2515CTNO	△		SCK2515STNO	△	25		15	50	21	27.1	M5	20	11	12.1	16.5	55.6	M6×32		
SCK3015CTNO	△		SCK3015STNO	△	30		15	56	23.5	30.5	M6	21	10.5	12.1	19	59.1	M6×40		
SCK3520CTNO	△		SCK3520STNO	△	35		20	65	26	39	M6	23	10.7	14.1	22.5	60.7	M6×40		
SCK4020CTNO	△		SCK4020STNO	△	40		20	70	30	36.1	M6	26	12.6	14.1	25	65.4	M6×50		
SCK5020CTNO	△		SCK5020STNO	△	50		20	85	37	41.8	M6	28	14.5	14.1	29.5	72.7	M6×50		

Ex. 使用例



訂貨： 交期： 天

SCK1015CTNS