

RoHS

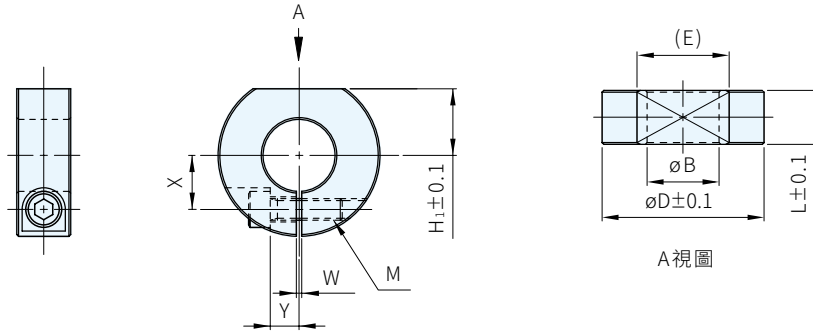

材質	處理	附屬品
S45C	染黑	六角螺栓(染黑)1支



品 號	庫 存	B +0.05 +0.01	L	D	D切面		W	X	Y	M
					H ₁	(E)				
SCS1515CT	△	15	15	40	17	21.1	1.5	13	8	M6×20
SCS2015CT	△	20	15	45	18.5	25.6	1.5	15	8	M6×20
SCS2515CT	△	25	15	50	21	27.1	1.5	18	10	M6×25
SCS3015CT	△	30	15	55	23.5	28.6	1.5	20	10	M6×25
SCS3515CT	△	35	15	60	26	29.9	2	23	12	M6×25
SCS4018CT	△	40	18	70	30	36.1	2	26	13	M8×30

 訂貨： 交期： 天

SCS1515CT