

RoHS SUS



染黑



SUS304

材質	處理	附屬品
S45C	染黑	楔型(SUS304/鍍鉬)1個 六角螺栓(SCM435/染黑)1支
SUS304	-	楔型(SUS304)1個 六角螺栓(SUS×M7)1支

∅B:10~16

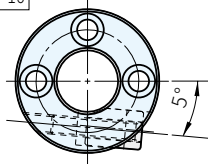

∅B:20~50

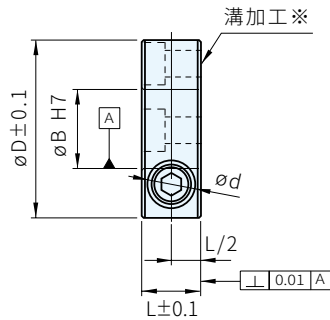
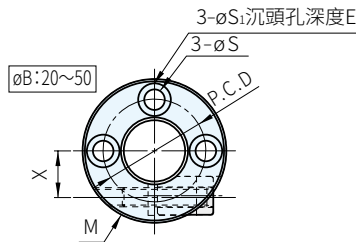

· 端面有溝側和對象物安裝在一起

S45C		SUS304		B	L	D	橫孔				d	X	M
品號	庫存	品號	庫存				S	P.C.D	S <sub>1</sub>	E			
SCK1015CZ3	·	SCK1015SZ3	△	10	15	35	4.5	24	7.5	4	12.1	9.5	M6×18
SCK1215CZ3	·	SCK1215SZ3	△	12	15	38	5.5	24	9	5	12.1	10.5	M6×18
SCK1515CZ3	·	SCK1515SZ3	△	15	15	40	6.6	28	10.5	6	12.1	12	M6×18
SCK1615CZ3	·	SCK1615SZ3	△	16	15	42	6.6	28	10.5	6	12.1	12	M6×18
SCK2015CZ3	·	SCK2015SZ3	△	20	15	46	6.6	34	10.5	6	12.1	14	M6×20
SCK2515CZ3	·	SCK2515SZ3	△	25	15	50	6.6	38	10.5	6	12.1	16.5	M6×20
SCK3015CZ3	△	SCK3015SZ3	△	30	15	56	6.6	44	10.5	6	12.1	19	M6×25
SCK3520CZ3	△	SCK3520SZ3	△	35	20	65	6.6	48	10.5	6	14.1	22.5	M6×35
SCK4020CZ3	△	SCK4020SZ3	△	40	20	70	6.6	56	10.5	6	14.1	25	M6×35
SCK5020CZ3	△	SCK5020SZ3	△	50	20	85	6.6	68	10.5	6	14.1	29.5	M6×35

Ex. 使用例

特殊形狀的楔型設計，以極小鎖緊力就可鎖固之

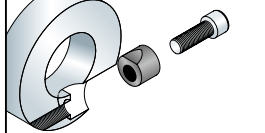

訂貨：  交期：  天 ·  
SCK1015CZ3  天 △