



齒面



平面



POM

名稱	材質	處理	硬度	顏色
本體	SCM440	染黑	-	-
珠子	SUS440	-	-	-
襯墊(齒面)	SKH51	染黑	HRC62	-
襯墊(平面)	SNCM220	染黑	HRC60	-
襯墊(塑膠)	POM	-	-	白

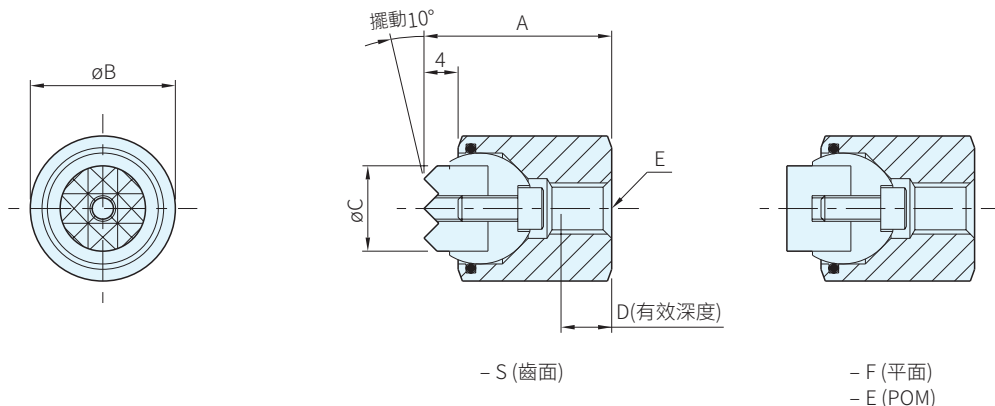

品號	襯墊材質	A	B 0 -0.13	C	D	E	許容荷重 (KN)注	質量 g	庫存
BBU-1722-S	SKH51	22	17	10	7.5	M6×1	18.4	31	△
BBU-1722-F	SNCM220							31	△
BBU-1722-E	POM							27	△
BBU-1924-S	SKH51	24	19	12	8.5	M8×1.25	24.5	43	△
BBU-1924-F	SNCM220							43	△
BBU-1924-E	POM							37	△
BBU-2428-S	SKH51	28	24	16	9.0	M10×1.5	43.6	72	△
BBU-2428-F	SNCM220							73	△
BBU-2428-E	POM							61	△
BBU-3030-S	SKH51	30	30	20	8.5	M12×1.75	57.7	128	△
BBU-3030-F	SNCM220							129	△
BBU-3030-E	POM							109	△
BBU-3636-S	SKH51	36	36	25	12.0	M12×1.75	85.6	235	△
BBU-3636-F	SNCM220							237	△
BBU-3636-E	POM							205	△

· 注)POM類型除外

**WA) 注意**

- 襯墊可以從球型內側，以附屬的六角螺絲安裝及拆卸
- BBU-S 1722~3636, BBU-F 1722~3636, BBU-E 1722~3636的襯墊，可用附屬的螺栓從內側押出
- BBU-S 1722~3636, BBU-F 1722~3636, BBU-E 1722~3636的襯墊固定螺栓鬆開後，也可交換襯墊

**Ex) 使用例**

訂貨：  交期：  天

BBU-1722-S

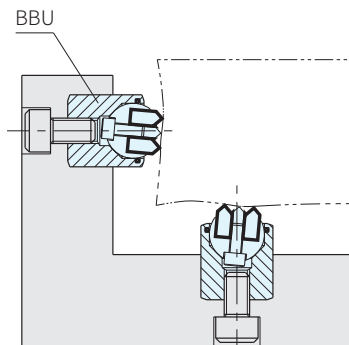

夾持及墊塊功能