



齒面



平面



POM

名稱	材質	處理	硬度	顏色
本體	SCM440	染黑	-	-
珠子(齒面)	SKH51	染黑	HRC60	-
珠子(平面)	SKH51	染黑	HRC60	-
珠子(塑膠)	POM	-	-	白

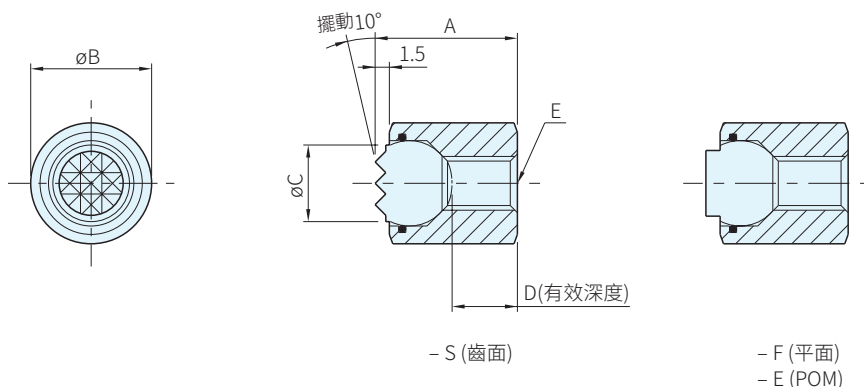

品號	珠子材質	A	B 0 -0.13	C	D	E	許容荷重 (KN)注	質量 g	庫存
BBU-1012-S	SKH51	12	10	6.0	3.5	M4×0.7	5.3	6	△
BBU-1025-S		25			9.0			13	△
BBU-1012-F	SKH51	12			3.5			6	△
BBU-1025-F		25			9.0			13	△
BBU-1012-E	POM	12			3.5			5	△
BBU-1025-E		25			9.0			12	△
BBU-1316-S	SKH51	16	13	8.5	6.5	M5×0.8	10.9	12	△
BBU-1325-S		25			9.0			21	△
BBU-1316-F	SKH51	16			6.5			12	△
BBU-1325-F		25			9.0			21	△
BBU-1316-E	POM	16			6.5			11	△
BBU-1325-E		25			9.0			20	△

· 注)POM類型除外

Ex. 使用例

訂貨：  交期：  天

BBU-1012-S

