

RoHS SUS



QCMA0612A



QCMA0612-M4

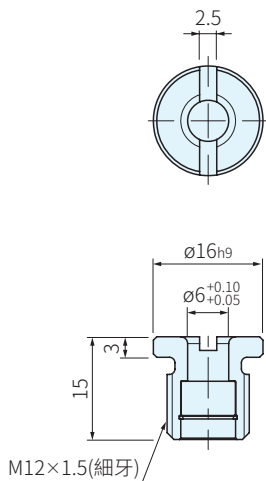

QCMA0612A

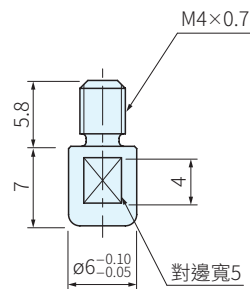

QCMA0612-M4

本體	磁鐵	夾頭
材質	材質	材質
SUS304	鈹磁鐵	S45C

品號	夾緊力 N	質量 g	庫存
QCMA0612A	7	12	△
QCMA0612-M4	-	2	△

SP. 特長

- 通過磁鐵將夾頭拉住

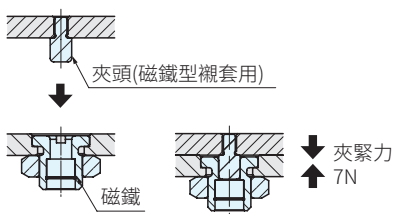

TE. 技術資料

- 耐熱溫度80°C
- 承載能力：剪切強度900N

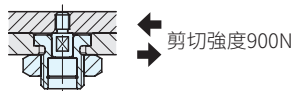

訂貨： 交期： 天
QCMA0612A

EX. 使用例

機械維護用外罩的裝拆

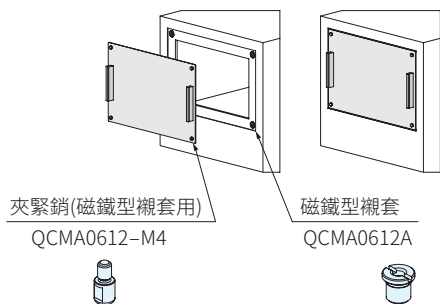

【選購品】 螺帽(不銹鋼製)

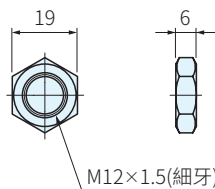

品號
NDX12-NUT-SUS

【選購品】 專用扳手

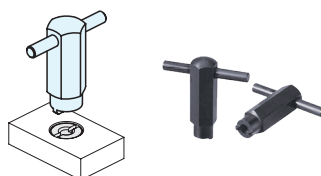

品號
PWW16

【磁性襯套的安裝方法】

6mm~10mm的板請用螺帽安裝

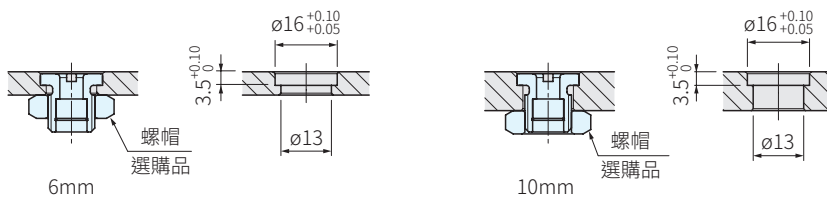

超過10mm的板請直接使用本產品安裝

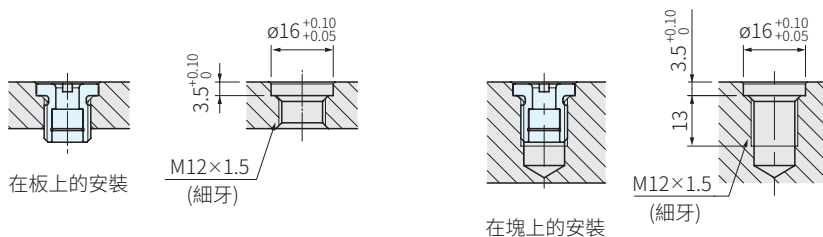

【夾頭的安裝方法】

2mm~6mm的板請用螺帽安裝

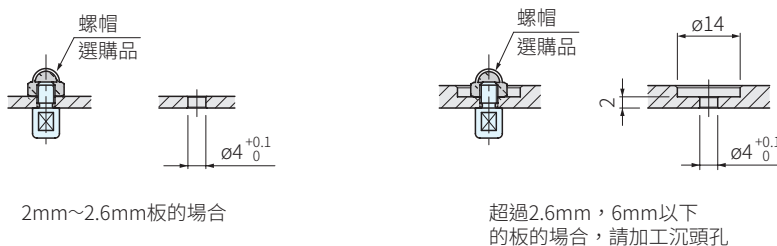

超過6mm的板請直接使用本產品安裝

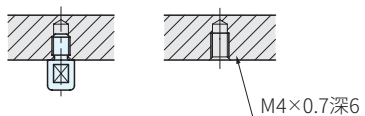

【加工精度和重覆定位精度】

■加工精度

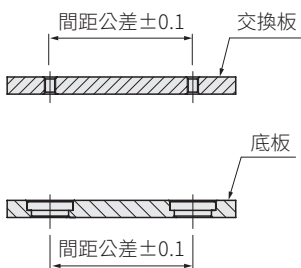

交換板和底板的間距公差，請按照±0.1加工

■重覆定位精度

·重覆定位精度為±0.25

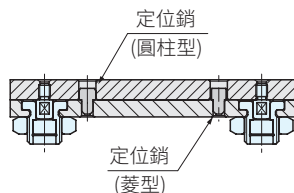

需要高精度的定位時，請與定位銷組合使用