

RoHS SUS

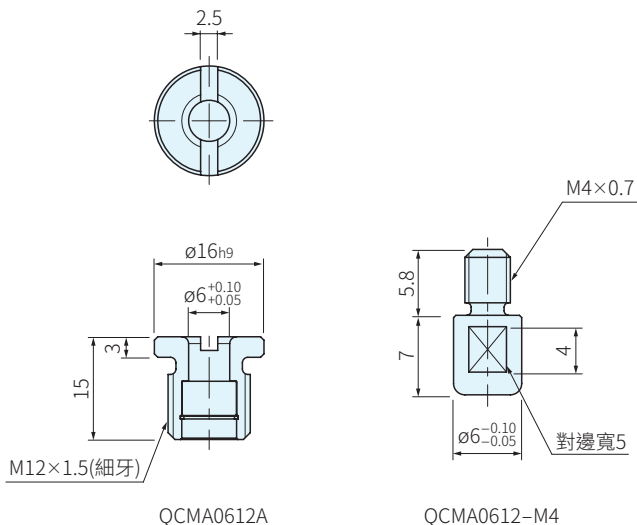
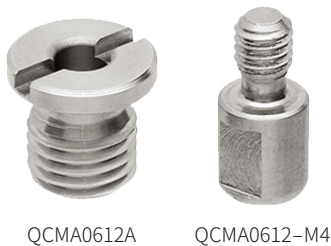

本體	磁鐵	夾頭
材質	材質	材質
SUS303	鈹磁鐵	S45C

品號	夾緊力 N	質量 g	庫存
QCMA0612A	7	12	△
QCMA0612-M4	-	2	△

**SP. 特長**

- 通過磁鐵將夾頭拉住

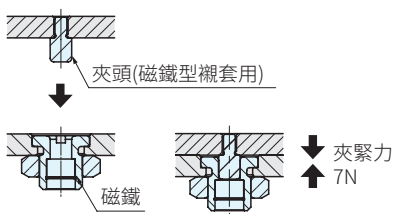

**TE. 技術資料**

- 耐熱溫度80°C
- 承載能力：剪切強度900N

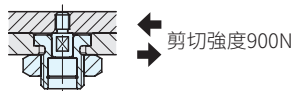

訂貨：  交期：  天  
QCMA0612A

**EX. 使用例**

機械維護用外罩的裝拆

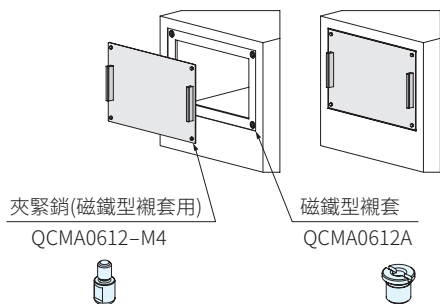

**【選購品】 螺帽(不銹鋼製)**

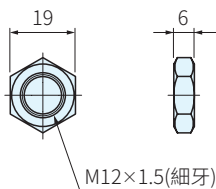

品號
NDX12-NUT-SUS

**【選購品】 專用扳手**

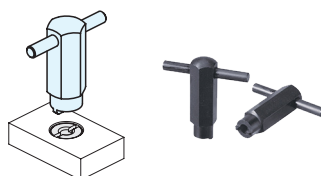

品號
PWW16

【磁性襯套的安裝方法】

6mm~10mm的板請用螺帽安裝

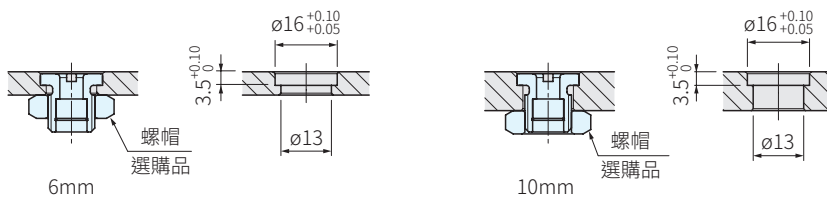

超過10mm的板請直接使用本產品安裝

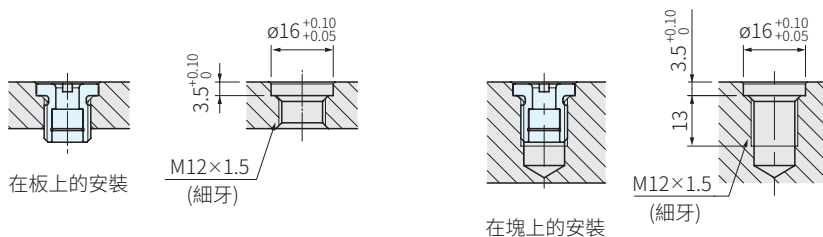

【夾頭的安裝方法】

2mm~6mm的板請用螺帽安裝

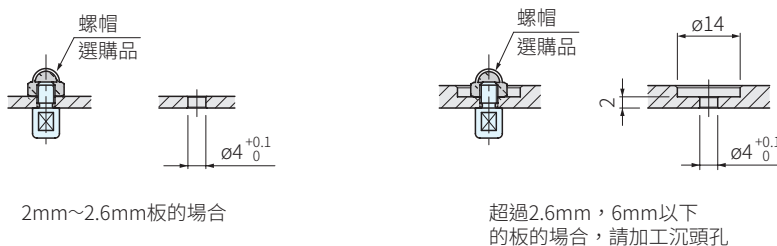

超過6mm的板請直接使用本產品安裝

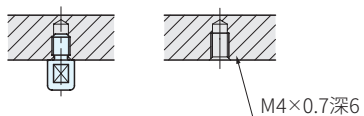

【加工精度和重覆定位精度】

■加工精度

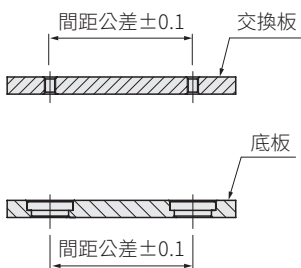

交換板和底板的間距公差，請按照±0.1加工

■重覆定位精度

· 重覆定位精度為±0.25

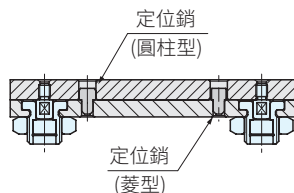

需要高精度的定位時，請與定位銷組合使用