



TYPE	本體	軸	銷子	旋鈕		彈簧A	彈簧B
	材質	材質	材質	材質	顏色	材質	材質
QCTHSA	SUS303	SKS3	SUS420J2	PA+玻纖	黑	SWOSC-V	SUS304WPB
QCTHSA-S	SUS303			SCS13	本色		



QCTHSA0825-20  
(樹脂旋鈕)



QCTHSA0825-20S  
(金屬旋鈕)

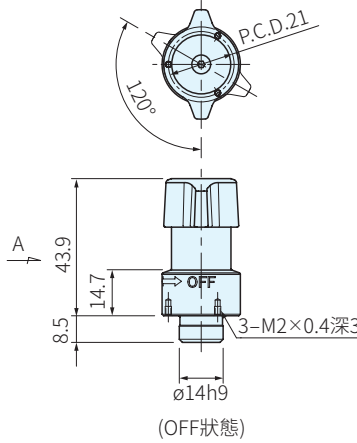

(OFF狀態)  
QCTHSA0825-20

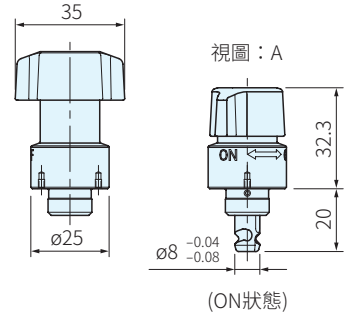

(ON狀態)  
QCTHSA0825-20S



QCTHSA0834-20  
(樹脂旋鈕)



QCTHSA0834-20S  
(金屬旋鈕)

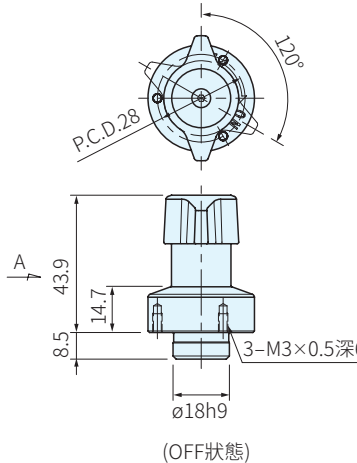

(OFF狀態)  
QCTHSA0834-20

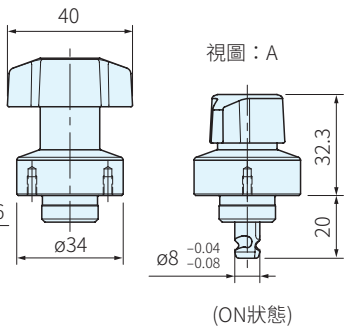

(ON狀態)  
QCTHSA0834-20S

品號	適用板厚度	夾緊力 N	質量 g	庫存	適用襯套
QCTHSA0825-20	※ 6~20	250	76	△	QCTHS0834-B
QCTHSA0825-20S			104	△	
QCTHSA0834-20		400	130	△	
QCTHSA0834-20S			160	△	

※在安裝小於9mm板上時，需使用QCTHSA專用墊片

訂貨：  交期：  天

QCTHSA0825-20

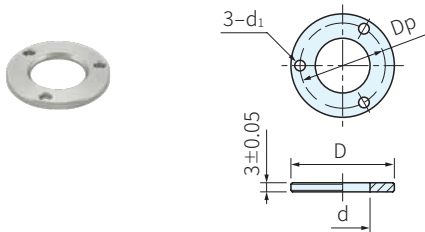

材質  
SUS303

品號	D	d +0.1/0	D <sub>p</sub>	d <sub>1</sub>	質量 g	庫存
QCTHSA25-03-SUS	25	14	21	2.3	7	△
QCTHSA34-03-SUS	34	18	28	3.5	14	△

訂貨：  交期：  天

QCTHSA25-03-SUS

附件

- QCTHSA/QCTHSA-S→0825-20：內六角螺栓(SUS製)M2×0.4-8L...3根
- QCTHSA/QCTHSA-S→0834-20：內六角螺栓(SUS製)M3×0.5-10L...3根

PS. 備註

- 使用配件：QCTHS-B
- 可搭配墊片一起使用



SP. 特長

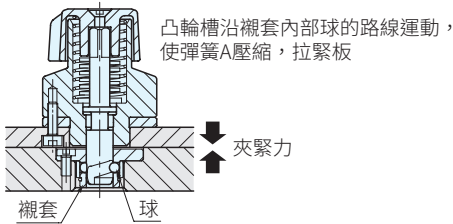
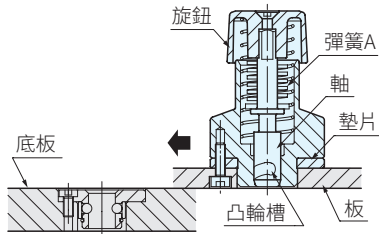

TE. 技術資料

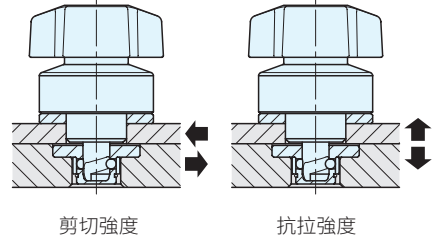

品號	耐熱溫度 °C	剪切強度 N	抗拉強度 N
QCTHSA0825-20	130	3000	1600
QCTHSA0825-20S	180		
QCTHSA0834-20	130		
QCTHSA0834-20S	180		

操作步驟

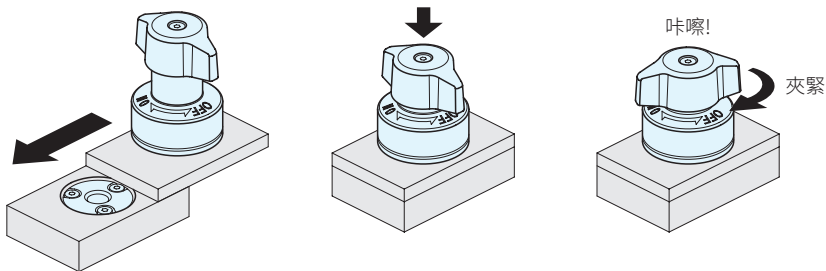

1.請確認旋鈕是否處於OFF的位置上  
(交換板可以滑動位移)

2.按下旋鈕

3.請將旋鈕轉至ON的位置，然後夾緊  
夾緊時有單擊感  
※鬆開時，請按相反的順序操作  
因彈簧反力會使銷子自動收縮進本體

EX. 使用例

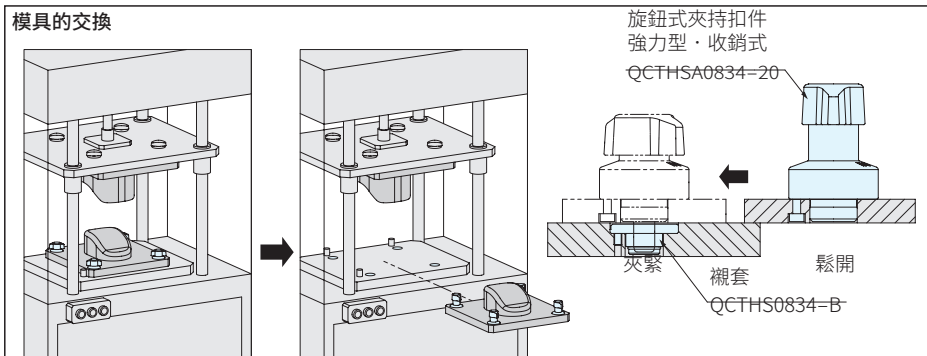

EX. 使用例

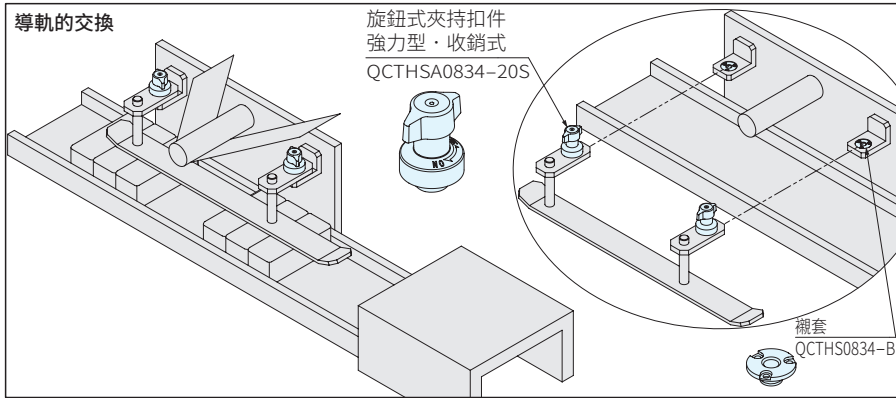

加工精度和重複定位精度

加工精度

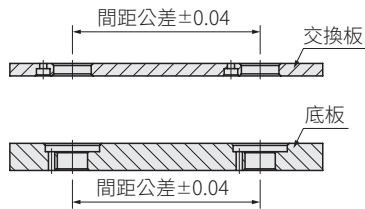

- 交換板和底板的間距公差，請按照±0.04加工

重複定位精度

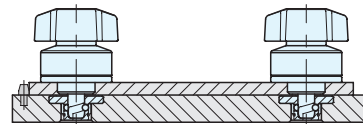
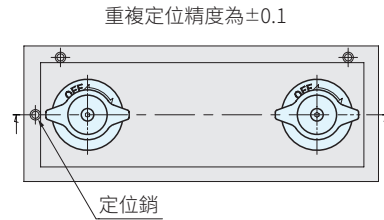

- 需要高精度的定位時，請與定位銷組合使用

PS. 備註

- 使用專用墊片：QCTHSA



旋鈕式夾持扣件(強力型・收銷式)的安裝方法

QCTHSA0825-20/QCTHSA0825-20S

板厚為9mm時

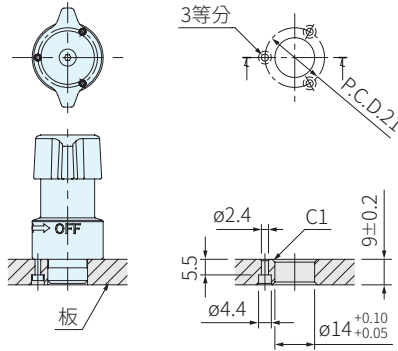

板厚為超過9mm，20mm以下時

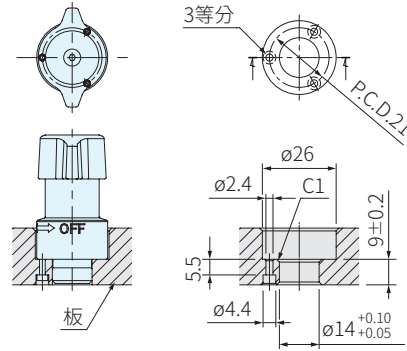

板厚為6mm時

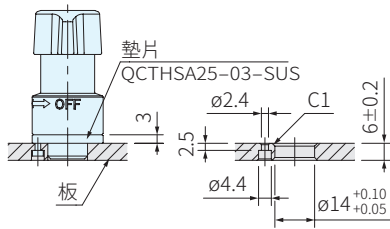

板厚為超過6mm，9mm以下時

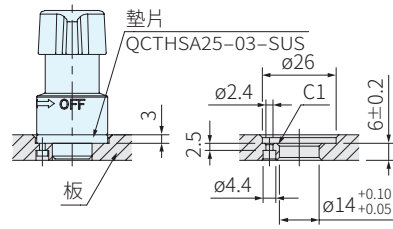

QCTHSA0834-20/QCTHSA0834-20S

板厚為9mm時

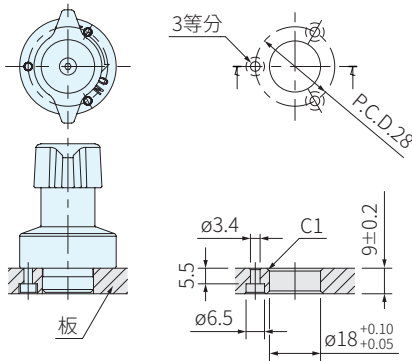

板厚為超過9mm，20mm以下時

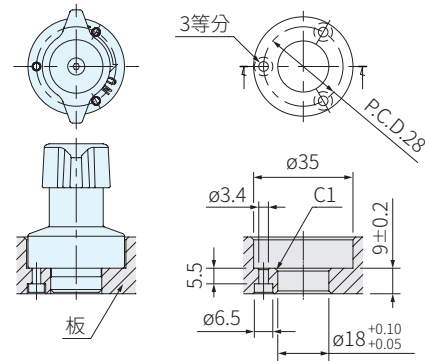

板厚為6mm時

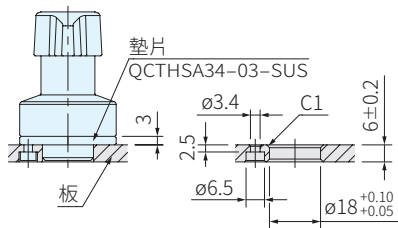

板厚為超過6mm，9mm以下時

