

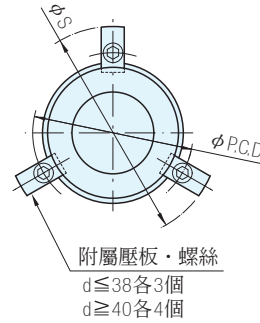

| 材質   | 硬度       |
|------|----------|
| SUJ2 | HRC60~64 |

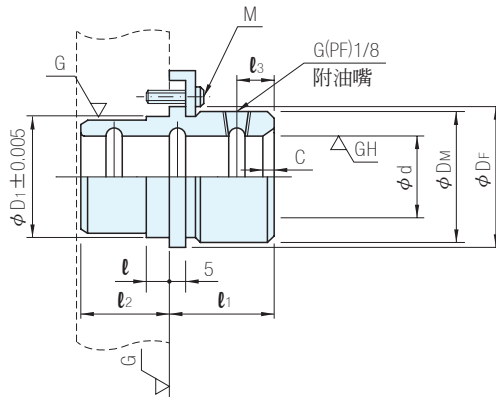

| 品號   |    | D1 | DF | DM | P.C.D | S  | M   | l1 | l2 | l3  | l | C   | 單價 |
|------|----|----|----|----|-------|----|-----|----|----|-----|---|-----|----|
| TYPE | d  |    |    |    |       |    |     |    |    |     |   |     |    |
| GBC  | 19 | 31 | 37 | 34 | 43    | 59 | M 4 | 32 | 27 | 12  | 7 | 2.0 | •  |
|      | 20 |    |    |    |       |    |     |    |    |     |   |     | •  |
|      | 22 |    |    |    |       |    |     |    |    |     |   |     | •  |
|      | 23 | 34 | 40 | 37 | 46    | 62 | •   |    |    |     |   |     |    |
|      | 24 | 37 | 43 | 40 | 51    | 69 | •   |    |    |     |   |     |    |
|      | 25 | 40 | 46 | 43 | 54    | 72 | •   |    |    |     |   |     |    |
|      | 27 | 40 | 46 | 43 | 54    | 72 | •   |    |    |     |   |     |    |
|      | 28 | 40 | 46 | 43 | 54    | 72 | •   |    |    |     |   |     |    |
|      | 31 | 44 | 50 | 47 | 60    | 80 | M 5 | 35 | 39 | 15  | 8 | 3.0 | •  |
|      | 32 | •  |    |    |       |    |     |    |    |     |   |     |    |
|      | 36 | •  |    |    |       |    |     |    |    |     |   |     |    |
|      | 37 | 51 | 57 | 54 | 67    | 87 | M 6 | 44 | 10 | 3.5 | • |     |    |
|      | 38 | •  |    |    |       |    |     |    |    |     |   |     |    |
|      | 40 | 54 | 60 | 57 | 70    | 90 |     | •  |    |     |   |     |    |
|      | 45 | 63 | 69 | 66 | 79    | 99 |     | 40 |    |     | • |     |    |
| 50   | 68 | 74 | 71 | 84 | 104   | 45 |     | 49 |    |     | • |     |    |
| 56   | 74 | 80 | 77 | 90 | 110   | •  |     |    |    |     |   |     |    |

**Wa. 注意**

- 精度標準請參閱脫料板·導柱·導套單元FUTABA導柱導套的精度基準
- 此產品是日本進口, 缺貨時交期較久, 請儘可能提前4週訂貨

**Ps. 備註**

- 模座導套專用之有機鉬強力潤滑劑請參閱化學產品單元S-00668

|     |       |     |      |               |
|-----|-------|-----|------|---------------|
| 訂貨: | 品號    | 交期: | 1 天  | d=20.22.24.25 |
|     | GBC19 |     | 20 天 | 28.32.36.38   |
|     |       |     |      | 其它            |