

TCC-PB | Mounting base for hinged joints

Technopolymer



- 1
- 2
- 3
- 4
- 5
- 6
- 7
- 8
- 9
- 10
- 11
- 12
- 13
- 14
- 15
- 16
- 17
- 18

BASE

Glass-fibre reinforced polyamide based (PA) technopolymer, RAL 9005 (C9) black colour or grey RAL 7040 (C33) colour, matte finish.

SCREW AND NUT (SUPPLIED)

Cylindrical-head screws with hexagon socket in AISI 304 stainless steel with anti-seizure treatment.

Self-locking nut in AISI 304 stainless steel.

STANDARD EXECUTIONS

- **TCC-PB-E**: external teeth.
- **TCC-PB-S**: without teeth.

FEATURES

A base with external teeth can be joined to a clamp with internal teeth, or a base without teeth to a clamp without teeth, to create a hinged joint. Joints comprising bases with external teeth and clamps with internal teeth (36 teeth) have a 10° adjustment angle.

Joints comprising bases and clamps without teeth can be positioned at any angle.

The "s" grub screw may be replaced by the kit TCC-KS.

TECHNICAL DATA

The resistance values shown in the table were measured during laboratory tests at ambient temperature with the screws tightened to the maximum torque "C#".

ACCESSORIES ON REQUEST (TO BE ORDERED SEPARATELY)

- TCC-KS (see page -): clamping kit.
- TCC-KV (see page -): screws and clamping nuts.



ELESA Original design

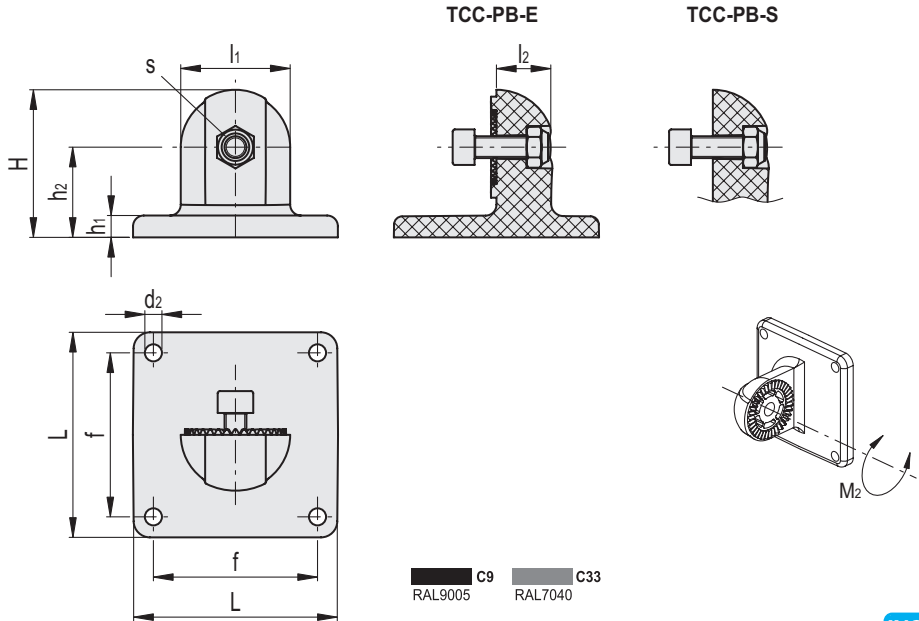

TCC-PB-E

Code	Description	L	H	d2	f ±0.2	h1	h2	l1	l2	s	C# [Nm]	M2*** [Nm]	⚖️
600421-C9	TCC-PB-30-E-C9	75	54	6.5	60	8	33	40	20	M8	12	100	78
600421-C33	TCC-PB-30-E-C33	75	54	6.5	60	8	33	40	20	M8	12	100	78

TCC-PB-S

600425-C9	TCC-PB-30-S-C9	75	54	6.5	60	8	33	40	20	M8	12	7	73
600425-C33	TCC-PB-30-S-C33	75	54	6.5	60	8	33	40	20	M8	12	7	73

Suggested torque for screw assembly.

*** Resistance to joint rotation.

Tube connectors

2