

- 1
- 2
- 3
- 4
- 5
- 6
- 7
- 8
- 9
- 10
- 11
- 12
- 13
- 14
- 15
- 16
- 17
- 18

CLAMP

Glass-fibre reinforced polyamide based (PA) technopolymer, RAL 9005 (C9) black colour or grey RAL 7040 (C33) colour, matte finish.

SCREWS AND NUTS

Cylindrical-head screw with hexagon socket in AISI 304 stainless steel with anti-seizure treatment.

Self-locking nuts in AISI 304 stainless steel.

Supplied: two screws and two nuts for versions TCC-AP-E and TCC-AP-S, one screw and one nut for version TCC-AP-I

STANDARD EXECUTIONS

- **TCC-AP-E**: external teeth.
- **TCC-AP-I**: internal teeth.
- **TCC-AP-S**: without teeth.

FEATURES

Two clamps, one with external teeth and one with internal teeth or two without teeth, can be joined to create a hinged joint.

Joints comprising clamps with external/internal teeth (36 teeth) have a 10° adjustment angle.

Joints comprising clamps without teeth can be positioned at any angle. Clamps for tubes with a diameter of 30 ± 0.2 mm.

For smaller diameter tubes, the hole reduction sleeve TCC-A can be used (ordered separately).

The "s" grub screws may be replaced by the kit TCC-KS.

TECHNICAL DATA

The resistance values shown in the table were measured during laboratory tests at ambient temperature with the screws tightened to the maximum torque "C#".

ACCESSORIES ON REQUEST (TO BE ORDERED SEPARATELY)

- TCC-A (see page -): reduction sleeves.
- TCC-KS (see page -): clamping kit.
- GN 197 (see page -): monitor mounts.
- TCC-KV (see page -): screws and clamping nuts.
- GN 990 (see page -): connecting tubes.



ELESA Original design

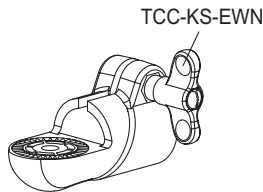
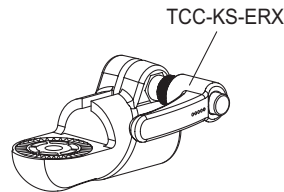

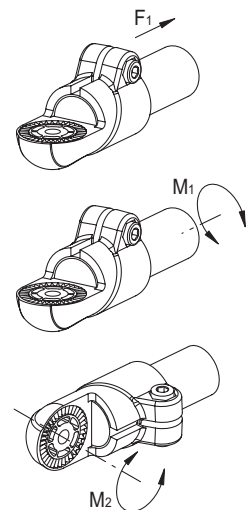
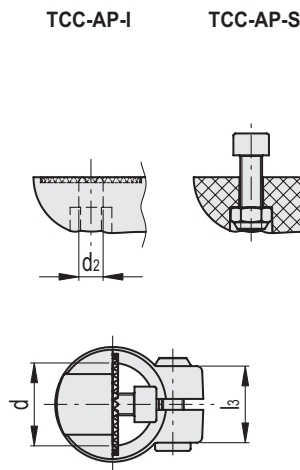
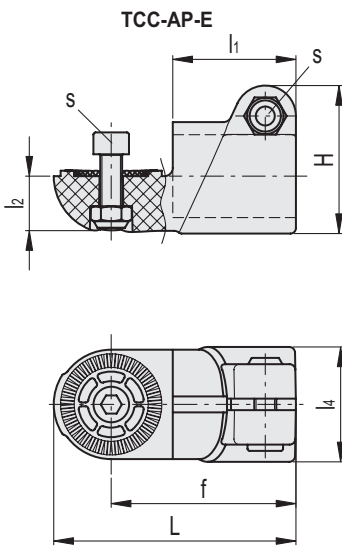

TCC-AP-E

Code	Description	d	L	H	f	l1	l2	l3	l4	s	C# [Nm]	F1* [N]	M1** [Nm]	M2*** [Nm]	⚖️
600401-C9	TCC-AP-30-E-C9	30	88	54	67	45	16.5	27	42	M8	12	3300	33	140	80
600401-C33	TCC-AP-30-E-C33	30	88	54	67	45	16.5	27	42	M8	12	3300	33	140	80

TCC-AP-I

Code	Description	d	L	H	d2	f	l1	l2	l3	l4	s	C# [Nm]	F1* [N]	M1** [Nm]	M2*** [Nm]	⚖️
600403-C9	TCC-AP-30-I-C9	30	88	54	8,1	67	45	16.5	27	42	M8	12	3300	33	140	79
600403-C33	TCC-AP-30-I-C33	30	88	54	8,1	67	45	16.5	27	42	M8	12	3300	33	140	79

TCC-AP-S

Code	Description	d	L	H	f	l1	l2	l3	l4	s	C# [Nm]	F1* [N]	M1** [Nm]	M2*** [Nm]	⚖️
600405-C9	TCC-AP-30-S-C9	30	88	54	67	45	16.5	27	42	M8	12	3300	33	6	79
600405-C33	TCC-AP-30-S-C33	30	88	54	67	45	16.5	27	42	M8	12	3300	33	6	79

Suggested torque for screw assembly.
 * Resistance to tube pull out
 ** Resistance to tube rotation
 *** Resistance to joint rotation.

