

- 1
- 2
- 3
- 4
- 5
- 6
- 7
- 8
- 9
- 10
- 11
- 12
- 13
- 14
- 15
- 16
- 17
- 18

CLAMP

Glass-fibre reinforced polyamide based (PA) technopolymer, RAL 9005 (C9) black colour or grey RAL 7040 (C33) colour, matte finish.

SCREW AND NUT (SUPPLIED)

Cylindrical-head screws with hexagon socket in AISI 304 stainless steel with anti-seizure treatment.

Self-locking nut in AISI 304 stainless steel.

FEATURES

Clamps for tubes with a diameter of 18 ± 0.2 and 30 ± 0.2 mm.

For smaller diameter tubes, the hole reduction sleeves TCC-A can be used (ordered separately).

The "s" grub screw may be replaced by the kit TCC-KS.

TECHNICAL DATA

The resistance values shown in the table were measured during laboratory tests at ambient temperature with the screws tightened to the maximum torque "C#".

ACCESSORIES ON REQUEST (TO BE ORDERED SEPARATELY)

- TCC-A (see page -): reduction sleeves.
- TCC-KS (see page -): clamping kit.
- TCC-KV (see page -): screws and clamping nuts.
- GN 990 (see page -): connecting tubes.



ELESA Original design

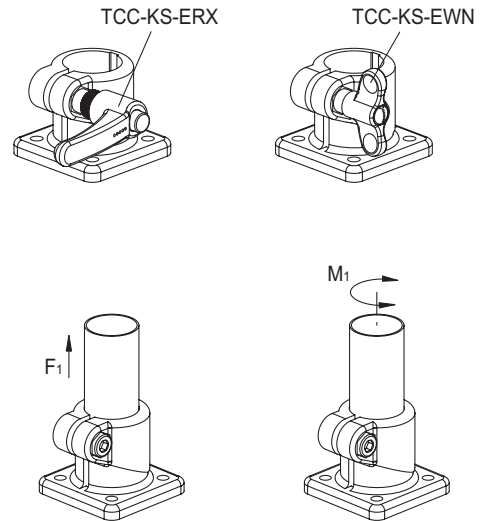
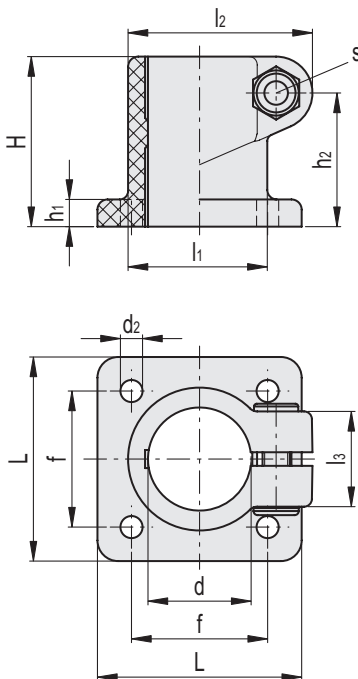

C9 RAL9005 C33 RAL7040

INOX STAINLESS STEEL

Code	Description	d	L	H	d2	f ±0.2	h1	h2	l1	l2	l3	s	C# [Nm]	F1* [N]	M1** [Nm]	
600111-C9	TCC-AB-18-C9	18	45	34	5.3	30	5	25	26	36.5	20	M6	5	1050	8	29
600111-C33	TCC-AB-18-C33	18	45	34	5.3	30	5	25	26	36.5	20	M6	5	1050	8	29
600211-C9	TCC-AB-30-C9	30	60	50	6.5	40	8	40	40	53.5	27	M8	12	1650	33	75
600211-C33	TCC-AB-30-C33	30	60	50	6.5	40	8	40	40	53.5	27	M8	12	1650	33	75

Suggested torque for screw assembly.

* Resistance to tube pull out

** Resistance to tube rotation

Tube connectors