

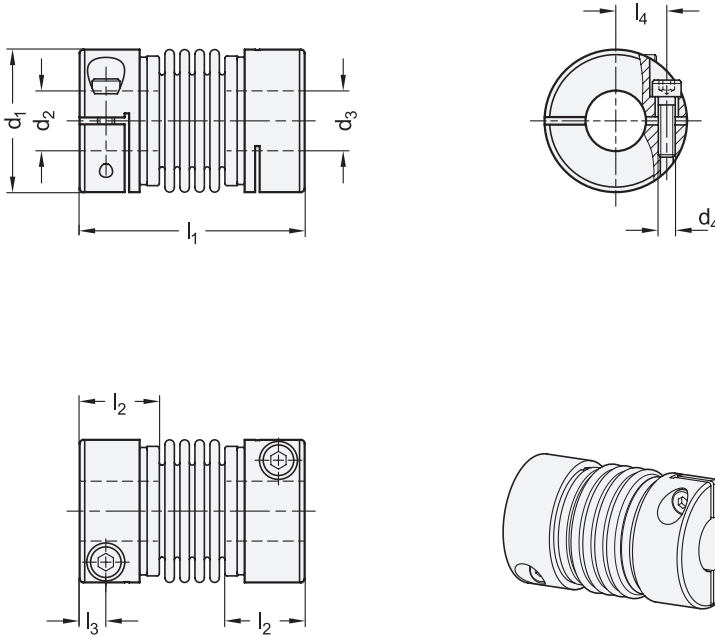

**2 Bore code**  
B without keyway



<b>1</b> $d_1$	<b>3</b> $d_2 - d_3$ H8 recommended shaft tolerance h7					
19	5-5	5-6	5-8	6-6	6-8	8-8
27	6-6	6-8	6-10	8-8	8-10	10-10
32	10-10	10-12	10-14	12-12	12-14	14-14
40	12-12	12-15	12-19	15-15	15-19	19-19

$d_1$	$d_4$	$l_1$	$l_2$ recommended shaft insertion depth	$l_3$	$l_4$	Tightening torque of the screw in Nm $\approx$
19	M 2	30	10,5	3	6,8	0,5
27	M 2,5	35	12,5	3,5	10,3	0,9
32	M 3	46	15,5	4,3	12	1,5
40	M 4	51	16	5	15	3,5

$d_1$	Rated torque in Nm	Max. speed (min <sup>-1</sup> )	Moment of inertia in kgm <sup>2</sup>	Static torsional stiffness in Nm/rad	Max. shaft misalignment		
					lateral in mm	axial in mm	angular in °
19	1,5	33.000	$8,6 \times 10^{-7}$	170	0,15	$\pm 0,5$	1,5
27	2,3	23.000	$3,6 \times 10^{-6}$	800	0,15	$\pm 0,5$	1,5
32	4,5	19.000	$1,1 \times 10^{-5}$	1600	0,2	$\pm 0,7$	1,5
40	10	15.000	$2,8 \times 10^{-5}$	2700	0,2	$\pm 1$	1,5



**Specification**

- Hub  
Aluminum anodized, natural color **AL**

---

- Bellows  
Stainless Steel AISI 304 **NI**

---

- Socket cap screws DIN 912  
Steel, blackened

---

- Crimp ring  
Brass

---

- temperature resistant up to 120 °C

---

- ISO-Fundamental tolerances  
→ Main Catalogue Page 1479

---

- Stainless Steel characteristics  
→ Main Catalogue Page 1489

• RoHS

**On request**

- Bore with keyway

**Information**

Bellows couplings GN 2244 transmit angle positions and torques with extreme precision and zero backlash. The metal bellows also reliably compensates for shaft misalignments and runout tolerances. The clamping hubs make bellows couplings very easy to install.

They are used in applications where precise position and movement transmission is required, such as in the servo drive systems of machine tools and in industrial robots.

see also...

- [Assembly instructions on couplings](#) → Page 22
- [Technical information on couplings](#) → Page 24
- [Beam couplings GN 2246](#) → Page 18
- [Elastomer jaw couplings GN 2240 \(with clamping hub\)](#) → Page 8

How to order

1	<b>d<sub>1</sub></b>
2	<b>Bore code</b>
3	<b>d<sub>2</sub> - d<sub>3</sub></b>
4	<b>Material (Hub)</b>
5	<b>Material (Bellows)</b>

1
2
3
4
5  
**GN 2244-40-B12-19-AL-NI**