

Side Mounting

With the slides fully extended, install cabinet member (outer member) with customer supplied 1/4" hex-head or pan head [M6 Euro] screws through the horizontal slots. Be sure slides are parallel. Attach drawer to extended inner member with customer supplied 1/4" hex-head or pan head [M6 Euro] screws through the vertical slots. Leave all screws loose for final adjustment. Adjust slide position until movement is smooth. Tighten all screws and if necessary, use more screws to secure slides and complete installation. See Figure 1.

Flat Mounting

Position large slide members on cabinet floor as shown in Figure 2. Make sure slides are parallel. Ensure slides are flush with edge of drawer bottom. With the slides fully extended, install cabinet member (outer member) with customer supplied 1/4" hex-head or pan head [M6 Euro] screws through the horizontal slots and secure in place. Install customer supplied 1/4" hex-head or pan head [M6 Euro] screws through vertical slots into the bottom of the drawer. Leave all screws loose for final adjustment. Adjust slide position until movement is smooth. Tighten all screws and if necessary, use more screws to secure slides and complete installation. See Figure 2.

Optional Platform Bracket Kits

Brackets provide four bottom-mount and two side-mount options. For bottom-mount, one bracket attaches to the slide outer member and the cabinet base. The other bracket attaches to the slide inner member and the platform or tray. For side-mount, the bracket attaches to the slide inner member. See Figure 3 for examples of both mounting options. When the brackets are used either individually or in combination, they will accommodate all slide lengths. Each kit contains two brackets, four 1/4" hex-head screws, and four 1/4" hex nuts with lock washers. See separate platform bracket data sheet for more information.

Slide Ordering Instructions

Complete your slide order for model 9301 by specifying the following:

	4 Pair	C	9301	-12	D
Total Required Slides	_____				
Slide Finish	_____				
Slide Model	_____				
Slide Length	_____				
Optional Distributor Packaging	_____				

Packaging

Distributor (D) Pack: One pair of slides packaged in polybag. **Mounting hardware not included.**

Slide Lengths: 10"-22" 4 pair per box
 24"-40" 2 pair per box
 42", 44", 48", 60" 1 pair per box

Bulk (P) Orders: Slides only.
 Slide Lengths: 10"-22" 4 pair per box
 24"-40" 2 pair per box
 42", 44", 48", 60" 1 pair per box

Specifications

Slide members: Cold rolled steel
 Ball retainers: Polymer
 Ball bearings: Carburized steel

NOTE: Specifications, materials, prices, terms, and delivery are subject to change without notice

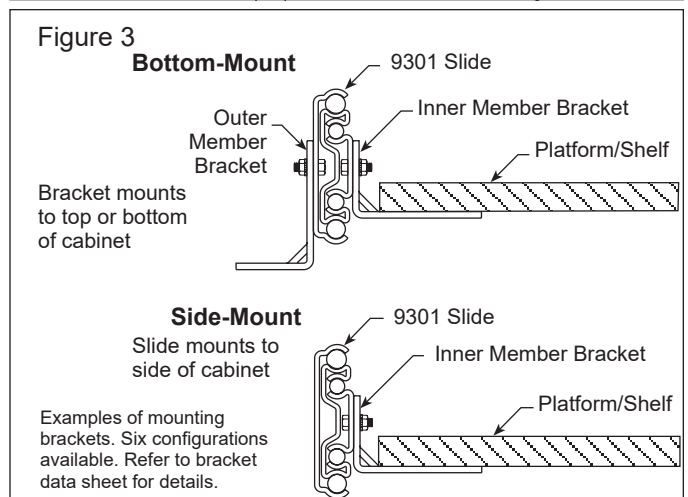
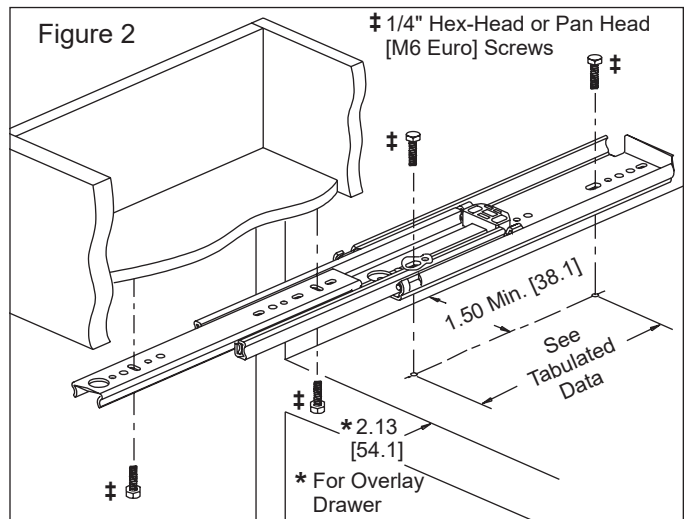
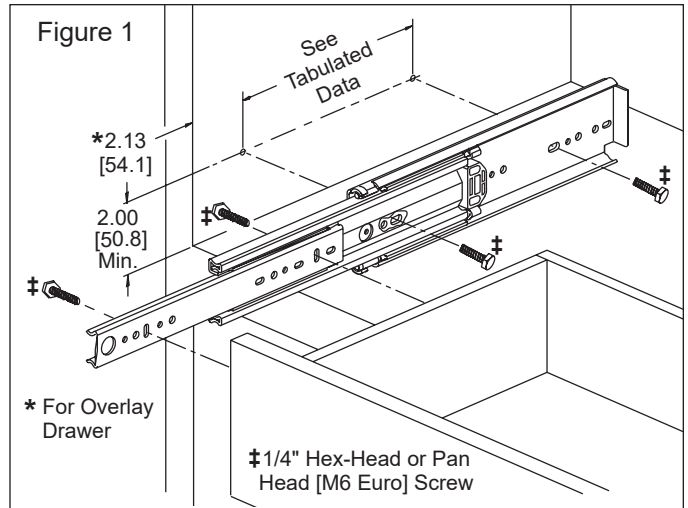

ACCURIDE INTERNATIONAL INC.

12311 Shoemaker Avenue
 Santa Fe Springs, CA 90670
 TEL (562) 903-0200
 FAX (562) 903-0208
 www.accuride.com

Manufacturing, Engineering, and Sales
 United States • Germany • Japan • Mexico • United Kingdom • China