

RoHS SUS



QCTH-N
(薄板用)



QCTH-N-SUS
(薄板用 · 不銹鋼型)



QCTH-B
(嵌入用)



QCTH-B-SUS
(嵌入用 · 不銹鋼型)

TYPE	本體	螺帽
	材質	材質
QCTH-N	SCM440	SUS
QCTH-B	SCM440	-
QCTH-N-SUS	SCS24	SUS
QCTH-B-SUS	SCS24	-

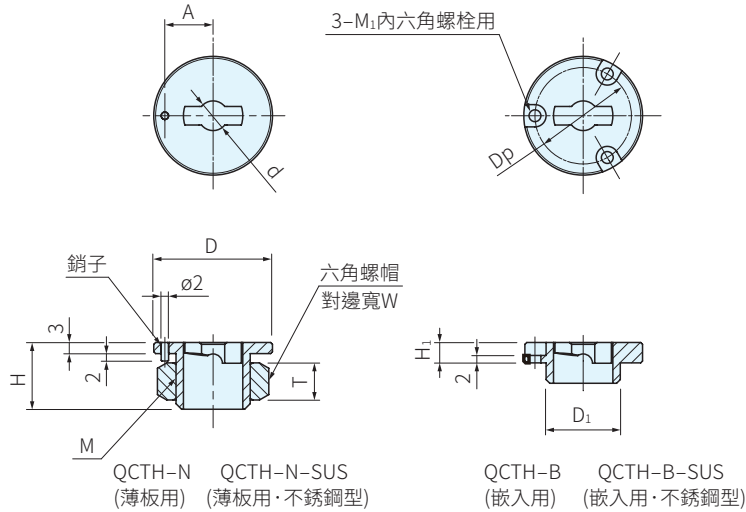

品號	適用板厚度	D	H	d +0.08 +0.04	A ±0.1	M	T	W	D ₁ -0.04 -0.08	H ₁	M ₁	Dp	旋鈕式夾持扣件		質量 g	庫存		
													品號	質量				
QCTH0525-N	薄板用	6~10	25	16	5	10.5	M14×1.5 細牙	8	22	-	-	-	-	QCTH	0525-10	40	△	
QCTH-S														0834-14	55	△		
QCTH0834-N		6~12	32	18	8	13	M20×1.5 細牙	10	30	-	-	-	-	QCTHL-S	0834-20	55	△	
QCTH-SUS														0834-20	55	△		
QCTH0525-B	嵌入用	超過10	25	9	5	-	-	-	14	4.5	M2	21	-	QCTHH	0525-10	20	△	
QCTHA														0525-10	20	△		
QCTH0525-B-SUS		超過12	32	11	8	-	-	-	-	20	5.5	M3	26	-	QCTHA-S	0834-14	35	△
QCTH-SUS															0834-20	35	△	

附件

- QCTH0525-B/QCTH0525-B-SUS : 內六角螺栓(SUS製)M2×0.4-5L...3根
- QCTH0834-B/QCTH0834-B-SUS : 內六角螺栓(SUS製)M3×0.5-6L...3根

訂貨: 交期: 天

QCTH0525-N

旋鈕式夾持扣件和襯套的安裝位置

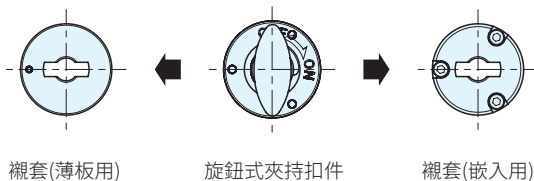

襯套的安裝方法

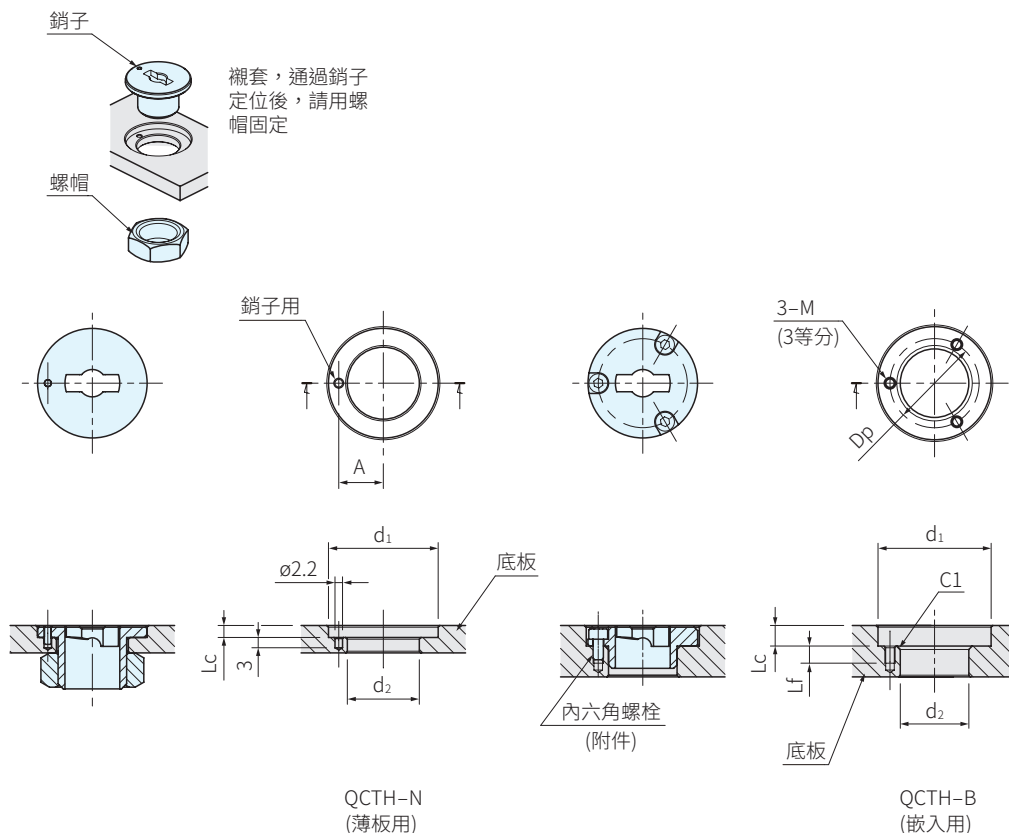

品號	適用 底板厚度	d ₁	d ₂	A ±0.1	Lc ^{+0.10} / ₀	M	Lf	Dp			
QCTH0525-N	薄板用	6~10	25	^{+0.10} / _{+0.05}	15	-	10.5	3.5	-	-	-
QCTH0525-N-SUS		6~12	32								
QCTH0834-N											
QCTH0834-N-SUS											
QCTH0525-B	嵌入用	超過10	26	-	14	^{+0.10} / _{+0.05}	-	5	M2×0.4	4	21
QCTH0525-B-SUS		超過12	33								
QCTH0834-B											
QCTH0834-B-SUS								6	M3×0.5	5	26