

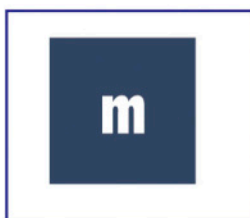

尺寸  
Size  
16 ~ 32



重量  
Weight  
0.7 ~ 3.07 g



力矩  
Moment  
1.5 ~ 9.3 Nm

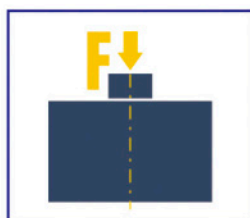

軸向力量  
Axial force  
78 ~ 451 N



轉距  
Torque  
2.4 ~ 9.7 Nm



- 1 MGB 迷你雙導桿氣缸模組  
MGB Mini dual guide rod cylinder module
- 2 SRB 通用型旋轉氣缸模組  
SRB Universal swivel unit
- 3 LGX 長行程小型二指平動機械夾爪  
LGX Long stroke small 2-jaw parallel gripper
- 4 LGY 小原件180度張角式機械夾爪  
LGY 180° angular gripper

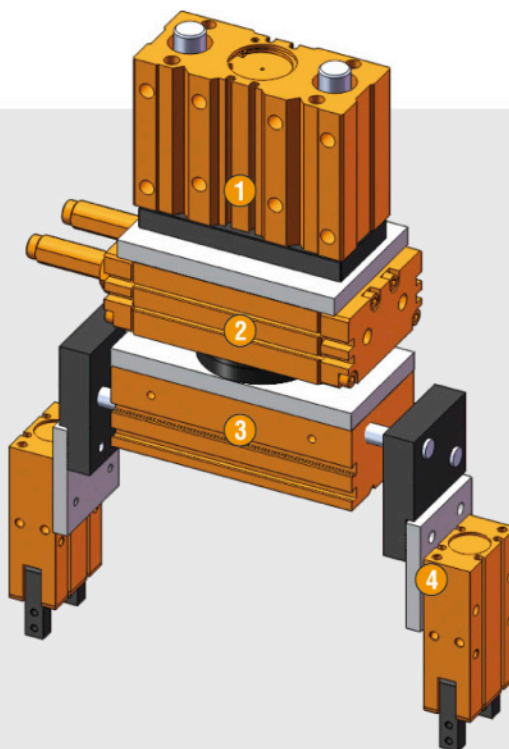

## 應用領域

- 自動化機構組成原件，提供了自動化更多的應用方式。
- 適用於機台製作或工廠生產、組裝及自動化產業的乾淨環境。

## 你的優勢

- 齒輪齒排設計：有絕佳之抗旋轉、扭力及側向負載能力。
- 用於旋轉運動180°旋轉氣缸模組，多種款式可供選擇。
- 配置兩個溝槽，安裝埋入式位置感應器。
- 空氣供給，確保在各式自動化系統中皆可彈性供給壓縮空氣。

## SRB 系列簡介

- 工作原理：齒輪齒排設計
- 外殼材質：鋁合金，超硬陽極處理
- 齒排材質：鋼
- 驅動方式：氣動：濾清壓縮空氣 (10mm) - 乾式、潤滑或非潤滑壓力介質：需求壓縮空氣品質等級 DIN ISO 8573-1
- 保固：12個月

## SRB Series Introduction

- How it works: Gear tooth row design.
- Shell material: Aluminum alloy, hard anodized.
- Tooth row material: Steel
- Drive: Pneumatic-filtration of compressed air \_ (10mm) \_- dry, lubricated or non-lubricated pressure medium: demand for compressed air quality level DIN ISO 8573-1
- Warranty: 12 months.

## Applications

- Automated mechanism composed the components, provides more automated application solutions.
- Suitable for clean environment of machine production or factory production, assemble and automation industry.

## Your advantage

- Gear tooth row design: great ability of anti-rotation, anti-torque and lateral load capacity.
- For 180 ° rotation cylinder module, several types available.
- Configuring two trenches, embedded position sensor included.
- Air supply, ensures that compressed air is supplied flexibly in all automated systems.



### ▶ SRB-16



作動壓力-工作扭矩關係圖  
Function pressure- working torque diagram

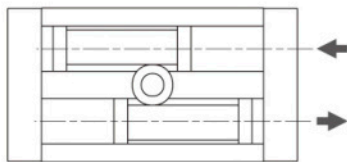

作動型式 Function type

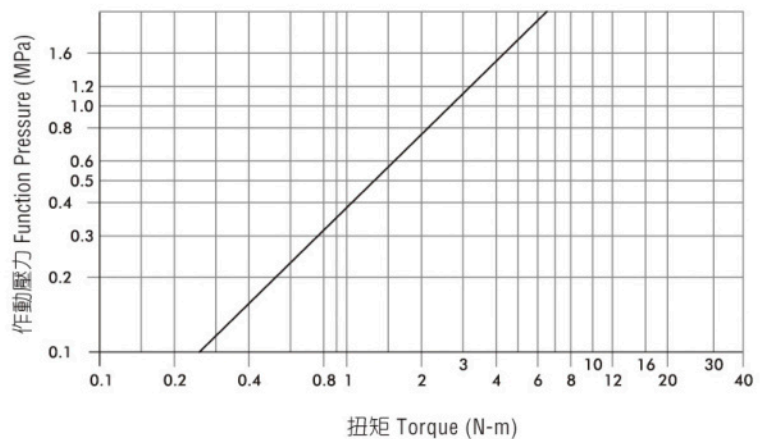

### 容許荷重 Allowable load

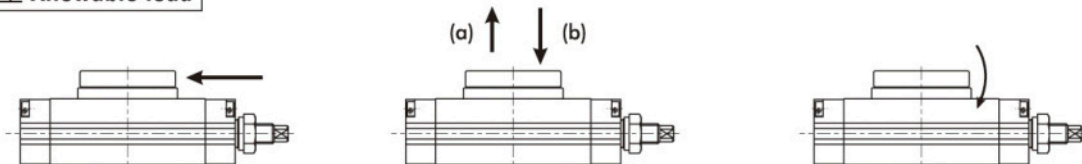

缸徑 Bore	容許徑向荷重 (N) Allowable radial load	容許荷重 Allowable load		容許力矩 (N.m) Allowable torque
		(a)	(b)	
16	78	74	78	2.4

### 技術資料 Technical data

型號 Model		<b>SRB-16</b>
扭力 Torque	Nm	1.5
旋轉角度 Rotation angle	°	0 ~ 190
容許運動能量 Allow movement of energy	(緩衝器 buffer)	0.039 個 (空氣緩衝 air buffer)
重量 Weight	kg	0.7
最小/最大最大壓力 Min. / Max. operating pressure	bar	1 ~ 9.9 kg + / cm <sup>2</sup>
額定工作壓力 Nominal operating pressure	bar	6
關閉/開啓時間 Closing / Opening time	s	0.5
IP等級 IP class	IP	40
最小/最大室溫 Min. / Max. ambient temperature	°C	-5° ~ 60°C
重複精度 Repeatability	mm	0.1

## 外觀尺寸圖 Dimensions

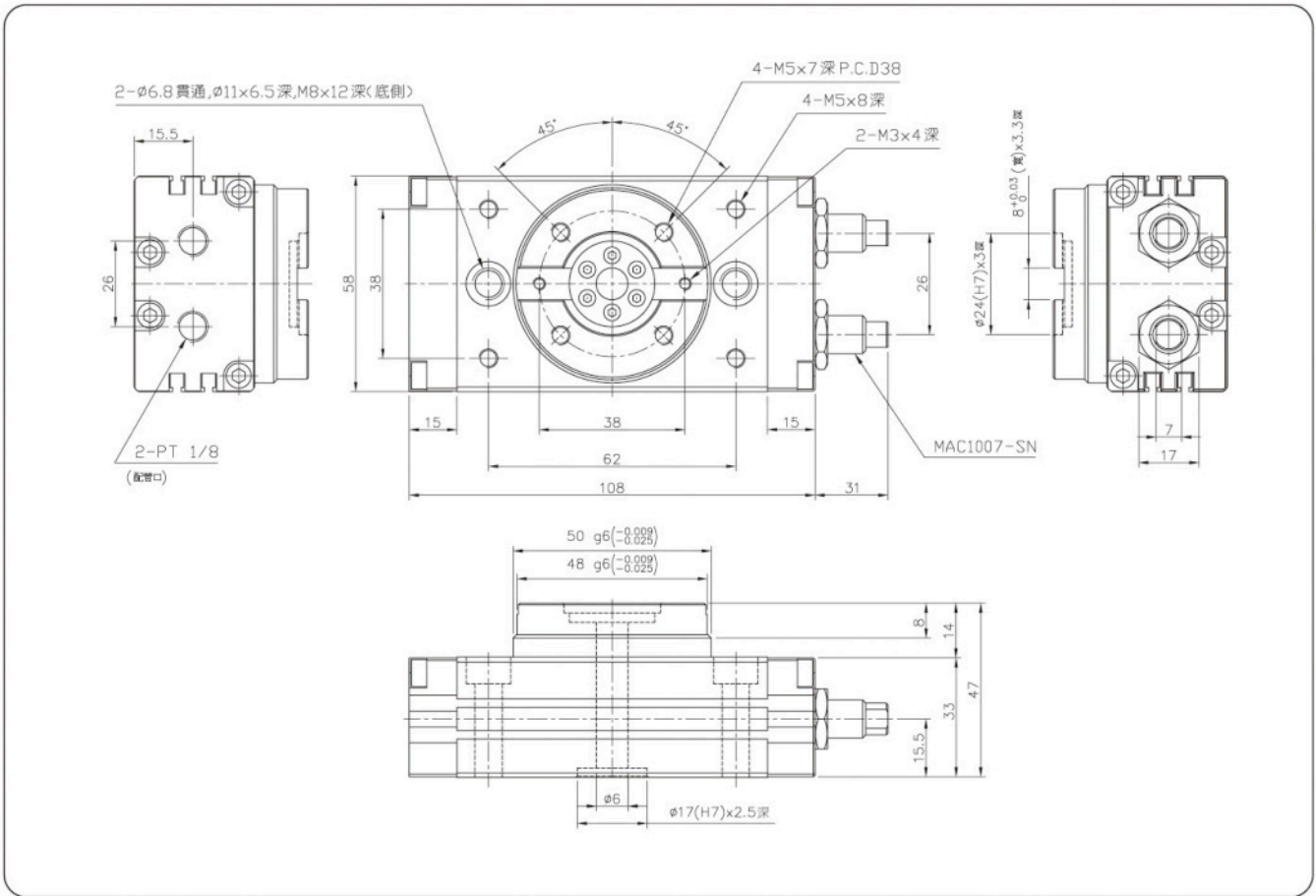

SRB-16

### (接觸式)C型槽感應器系統 (Contact) C-slot sensor system

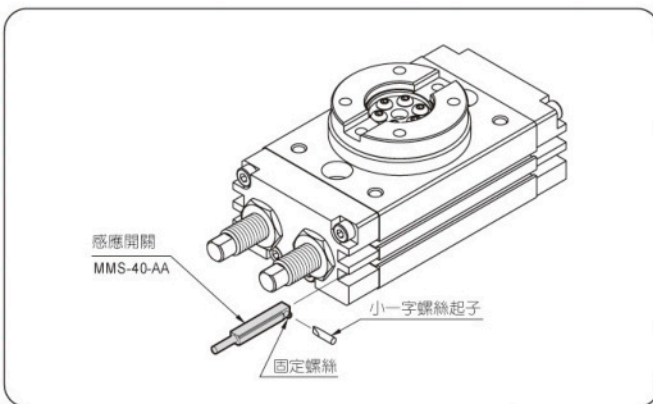

- 接觸式C型槽終端位置監控: 夾爪磁簧感應器, 安裝於夾爪C型槽內。
- 每個機械夾爪需要至少2個感應器(接觸式)。
- Contact C-slot terminal position monitoring: Gripper magnetic field sensor, installed in the C-slot.
- Each mechanical gripper needs at least two sensors (contact).

型號 Model	型式 Description	建議使用數量 Recom. number of use
MMS-40	直行設計 (兩線無接點) Straight design (two-line non-contact)	2

### 夾爪調速閥 Speed control valve

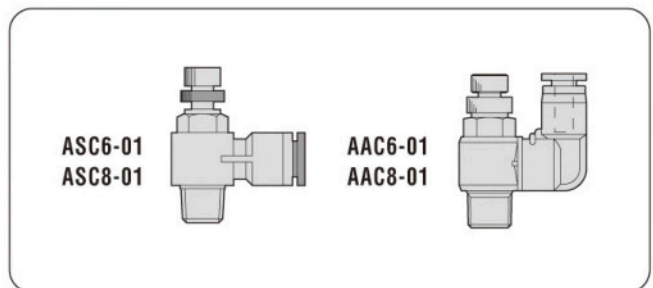

- 夾爪專用調速閥: 調整夾爪開張速度專用調速閥門。
- 每個機械夾爪需要至少2個調速閥。
- Speed control valve special for grippers: Special for adjusting the opening speed of gripper.
- Each mechanical gripper needs at least two speed control valves.

型號 Model	型式 Description	建議使用數量 Recom. number of use
ASC6-01	90度設計 $\phi 6$ 管徑 90 degrees design $\phi 6$ diameter	2
ASC8-01	90度設計 $\phi 8$ 管徑 90 degrees design $\phi 8$ diameter	2
AAC6-01	直通設計 $\phi 6$ 管徑 Through design $\phi 6$ diameter	2
AAC8-01	直通設計 $\phi 8$ 管徑 Through design $\phi 8$ diameter	2





### SRB-20

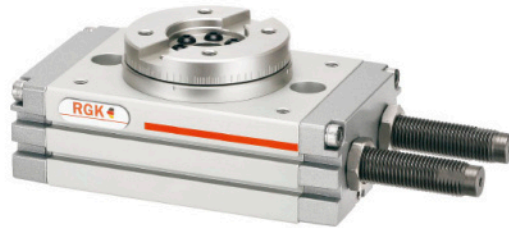

作動壓力-工作扭矩關係圖  
Function pressure- working torque diagram

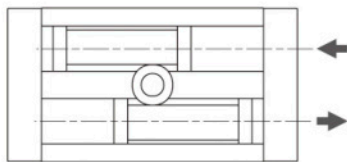

作動型式 Function type

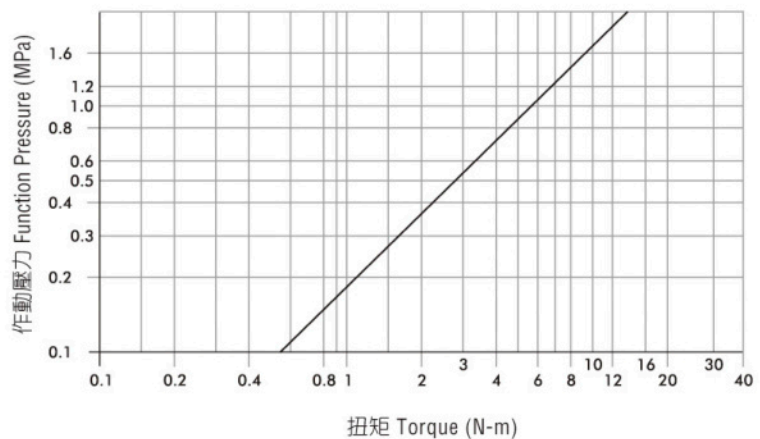

容許荷重 Allowable load

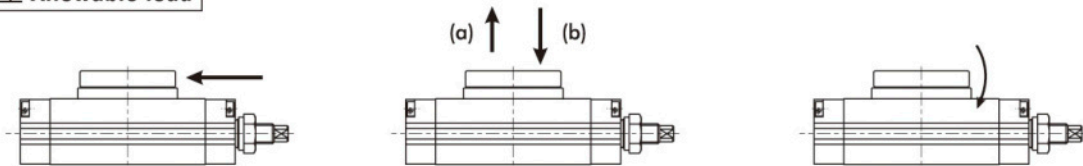

缸徑 Bore	容許徑向荷重 (N) Allowable radial load	容許荷重 Allowable load		容許力矩 (N.m) Allowable torque
		(a)	(b)	
20	147	137	137	4.0

技術資料 Technical data

型號 Model		<b>SRB-20</b>
扭力 Torque	Nm	3
旋轉角度 Rotation angle	°	0 ~ 190
容許運動能量 Allow movement of energy	(緩衝器 buffer)	0.116 個 (空氣緩衝 air buffer)
重量 Weight	kg	1.16
最小/最大最大壓力 Min. / Max. operating pressure	bar	1 ~ 9.9 kg + / cm <sup>2</sup>
額定工作壓力 Nominal operating pressure	bar	6
關閉/開啓時間 Closing / Opening time	s	0.5
IP等級 IP class	IP	40
最小/最大室溫 Min. / Max. ambient temperature	°C	-5° ~ 60°C
重複精度 Repeatability	mm	0.1

## 外觀尺寸圖 Dimensions

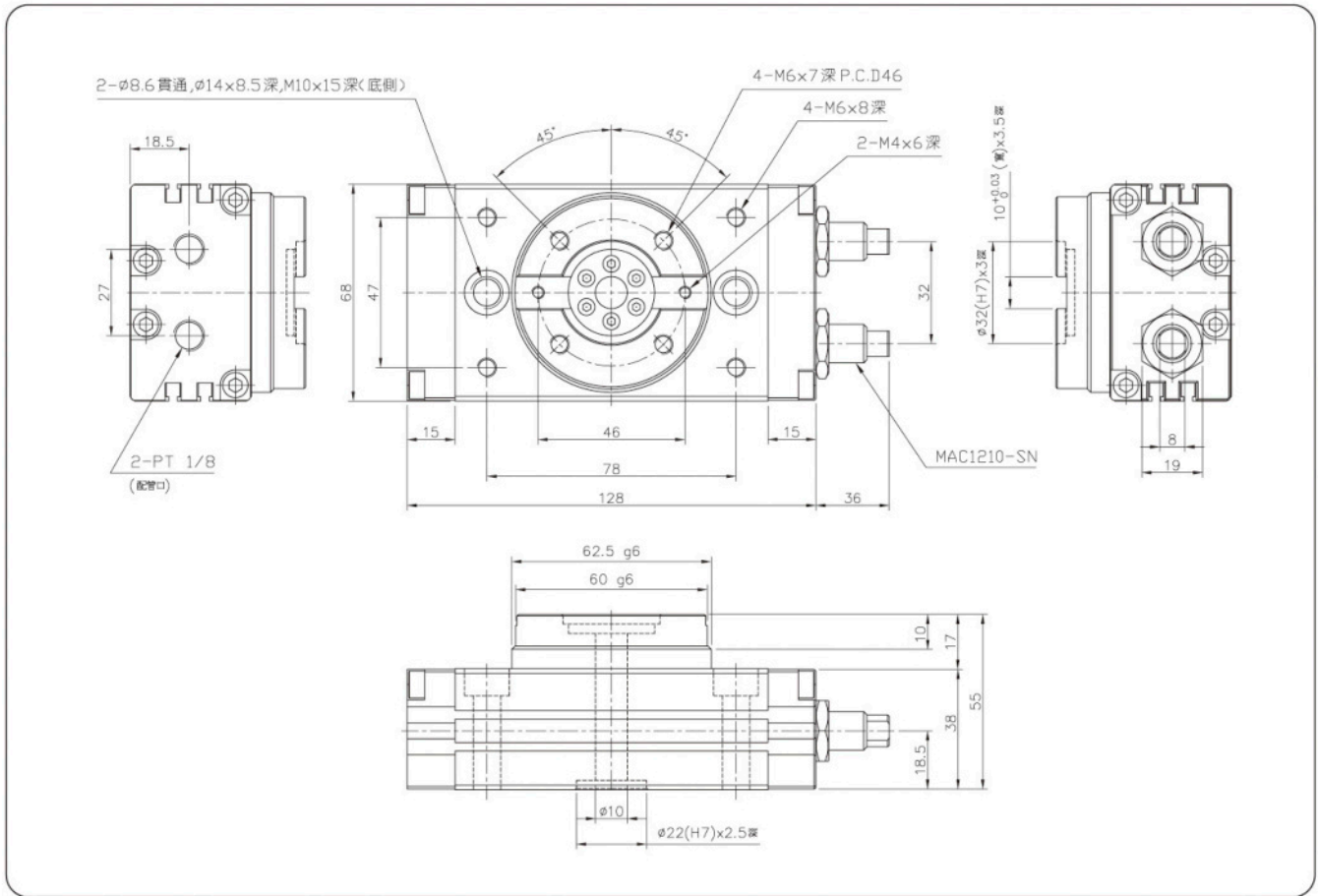

SRB-20

### (接觸式)C型槽感應器系統 (Contact) C-slot sensor system

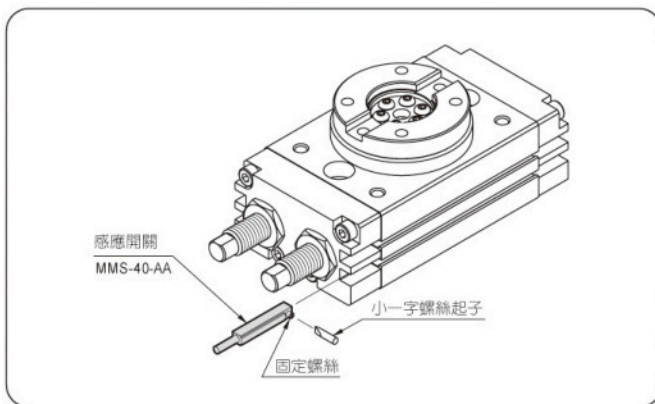

- 接觸式C型槽終端位置監控: 夾爪磁簧感應器, 安裝於夾爪C型槽內。
- 每個機械夾爪需要至少要2個感應器(接觸式)。
- Contact C-slot terminal position monitoring: Gripper magnetic field sensor, installed in the C-slot.
- Each mechanical gripper needs at least two sensors (contact).

型號 Model	型式 Description	建議使用數量 Recom. number of use
MMS-40	直行設計 (兩線無接點) Straight design (two-line non-contact)	2

### 夾爪調速閥 Speed control valve

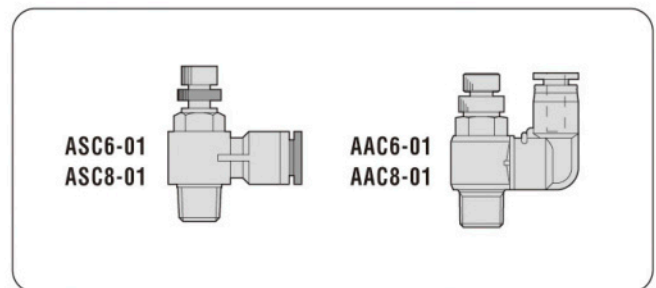

- 夾爪專用調速閥: 調整夾爪開張速度專用調速閥門。
- 每個機械夾爪需要至少要2個調速閥。
- Speed control valve special for grippers: Special for adjusting the opening speed of gripper.
- Each mechanical gripper needs at least two speed control valves.

型號 Model	型式 Description	建議使用數量 Recom. number of use
ASC6-01	90度設計 $\phi 6$ 管徑 90 degrees design $\phi 6$ diameter	2
ASC8-01	90度設計 $\phi 8$ 管徑 90 degrees design $\phi 8$ diameter	2
AAC6-01	直通設計 $\phi 6$ 管徑 Through design $\phi 6$ diameter	2
AAC8-01	直通設計 $\phi 8$ 管徑 Through design $\phi 8$ diameter	2



### SRB-25



作動壓力-工作扭矩關係圖  
Function pressure- working torque diagram

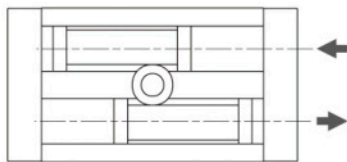

作動型式 Function type

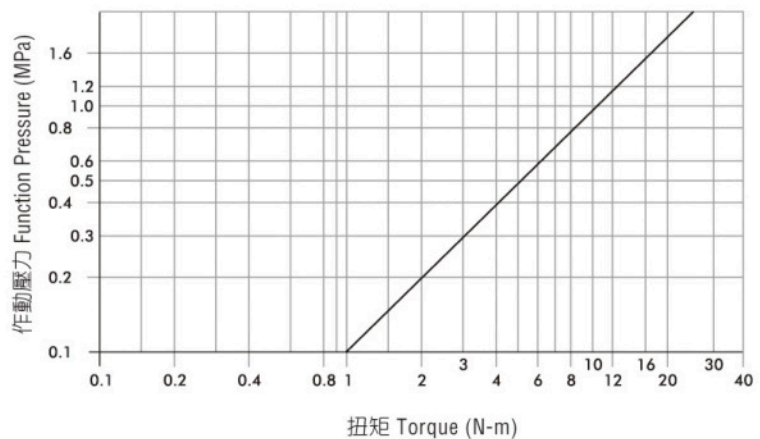

容許荷重 Allowable load

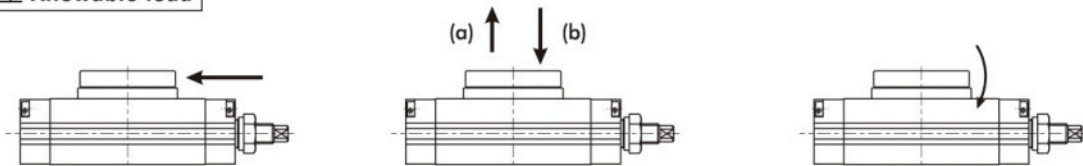

缸徑 Bore	容許徑向荷重 (N) Allowable radial load	容許荷重 Allowable load		容許力矩 (N.m) Allowable torque
		(a)	(b)	
25	196	197	363	5.3

技術資料 Technical data

型號 Model		<b>SRB-25</b>
扭力 Torque	Nm	4.7
旋轉角度 Rotation angle	°	0 ~ 190
容許運動能量 Allow movement of energy	(緩衝器 buffer)	0.29 個 (空氣緩衝 air buffer)
重量 Weight	kg	1.57
最小/最大最大壓力 Min. / Max. operating pressure	bar	1 ~ 9.9 kg + / cm <sup>2</sup>
額定工作壓力 Nominal operating pressure	bar	6
關閉/開啓時間 Closing / Opening time	s	0.5
IP等級 IP class	IP	40
最小/最大室溫 Min. / Max. ambient temperature	°C	-5° ~ 60°C
重複精度 Repeatability	mm	0.1

## 外觀尺寸圖 Dimensions

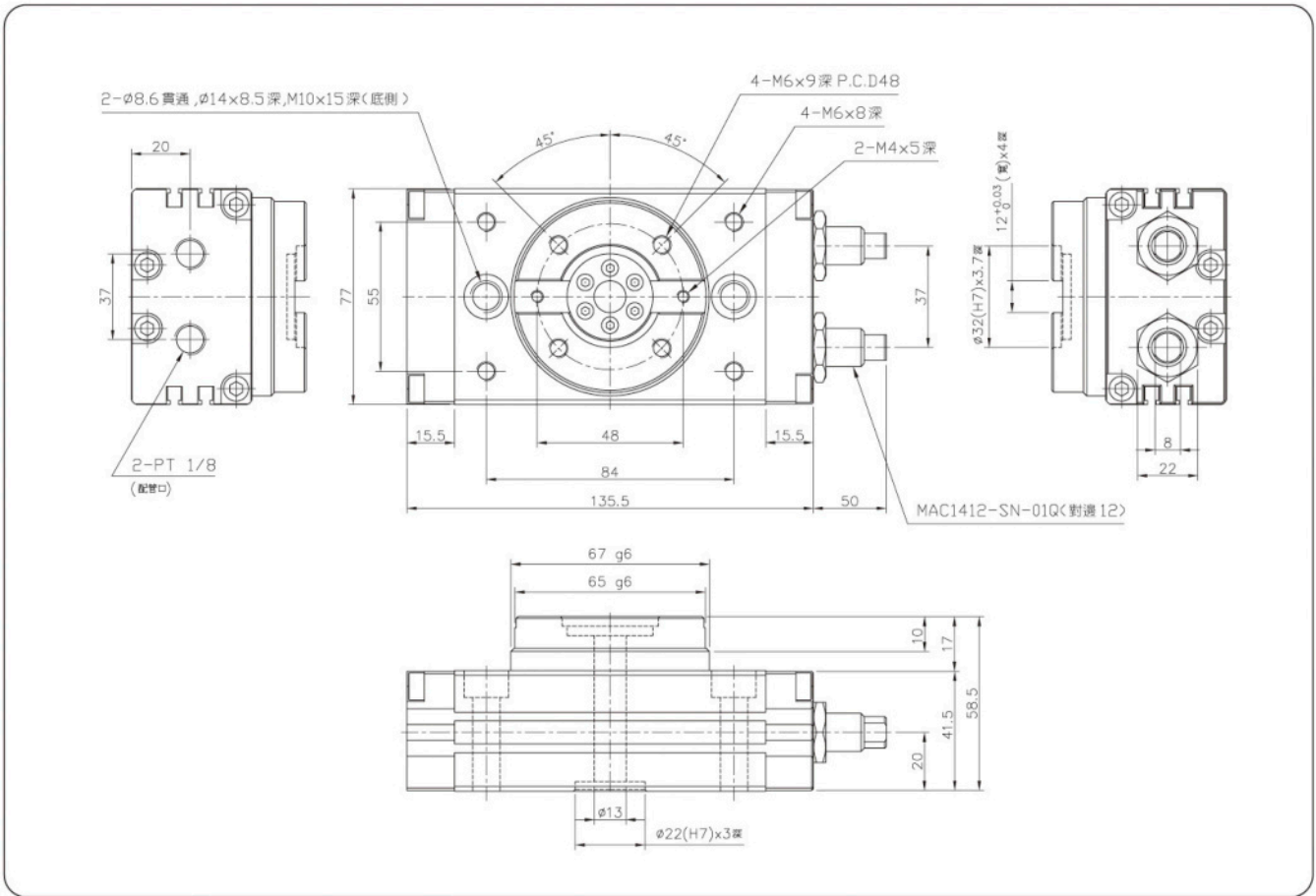

SRB-25

### (接觸式)C型槽感應器系統 (Contact) C-slot sensor system

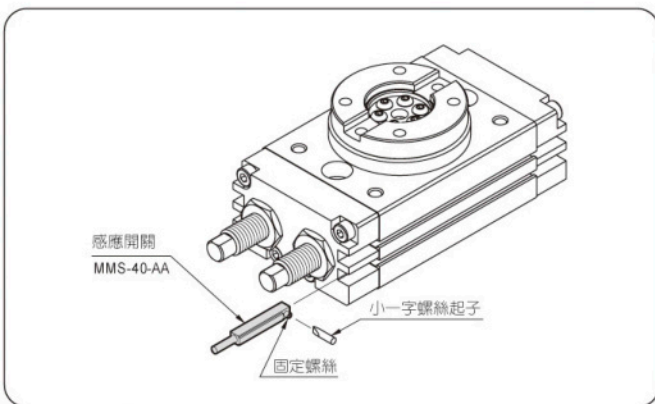

- 接觸式C型槽終端位置監控: 夾爪磁簧感應器, 安裝於夾爪C型槽內。
- 每個機械夾爪需要至少2個感應器(接觸式)。
- Contact C-slot terminal position monitoring: Gripper magnetic field sensor, installed in the C-slot.
- Each mechanical gripper needs at least two sensors (contact).

型號 Model	型式 Description	建議使用數量 Recom. number of use
MMS-40	直行設計(兩線無接點) Straight design (two-line non-contact)	2

### 夾爪調速閥 Speed control valve

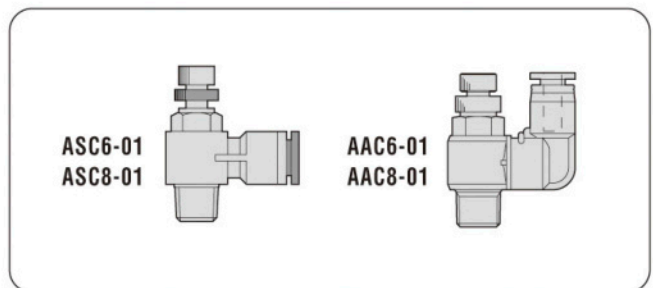

- 夾爪專用調速閥: 調整夾爪開張速度專用調速閥門。
- 每個機械夾爪需要至少2個調速閥。
- Speed control valve special for grippers: Special for adjusting the opening speed of gripper.
- Each mechanical gripper needs at least two speed control valves.

型號 Model	型式 Description	建議使用數量 Recom. number of use
ASC6-01	90度設計 $\phi 6$ 管徑 90 degrees design $\phi 6$ diameter	2
ASC8-01	90度設計 $\phi 8$ 管徑 90 degrees design $\phi 8$ diameter	2
AAC6-01	直通設計 $\phi 6$ 管徑 Through design $\phi 6$ diameter	2
AAC8-01	直通設計 $\phi 8$ 管徑 Through design $\phi 8$ diameter	2



### ▶ SRB-32

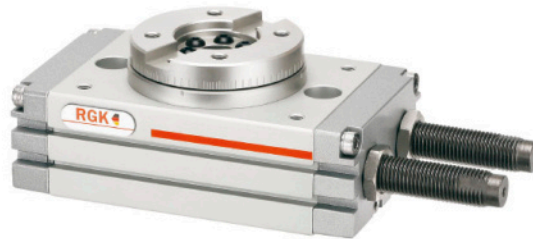

作動壓力-工作扭矩關係圖  
Function pressure- working torque diagram

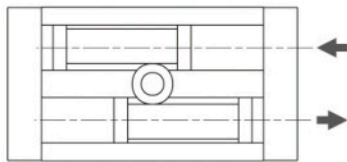

作動型式 Function type

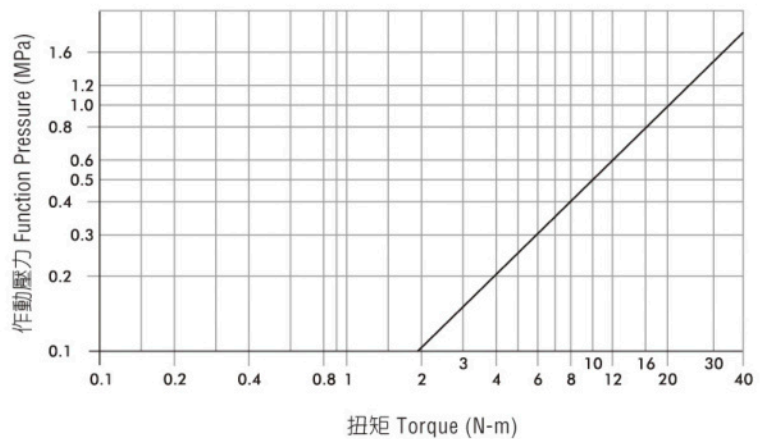

### 容許荷重 Allowable load

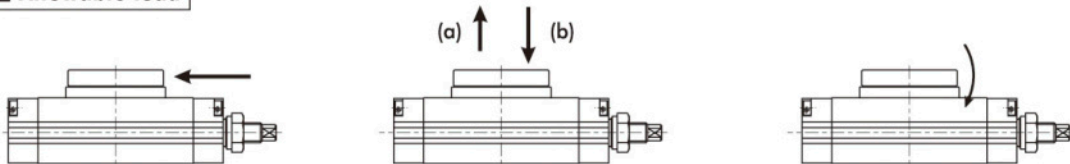

缸徑 Bore	容許徑向荷重 (N) Allowable radial load	容許荷重 Allowable load		容許力矩 (N.m) Allowable torque
		(a)	(b)	
32	314	296	451	9.7

### 技術資料 Technical data

型號 Model		<b>SRB-32</b>
扭力 Torque	Nm	9.3
旋轉角度 Rotation angle	°	0 ~ 190
容許運動能量 Allow movement of energy (緩衝器 buffer)		1.6 個 (空氣緩衝 air buffer)
重量 Weight	kg	3.07
最小/最大最大壓力 Min. / Max. operating pressure	bar	1 ~ 9.9 kg + / cm <sup>2</sup>
額定工作壓力 Nominal operating pressure	bar	6
關閉/開啓時間 Closing / Opening time	s	0.5
IP等級 IP class	IP	40
最小/最大室溫 Min. / Max. ambient temperature	°C	-5° ~ 60°C
重複精度 Repeatability	mm	0.1

## 外觀尺寸圖 Dimensions

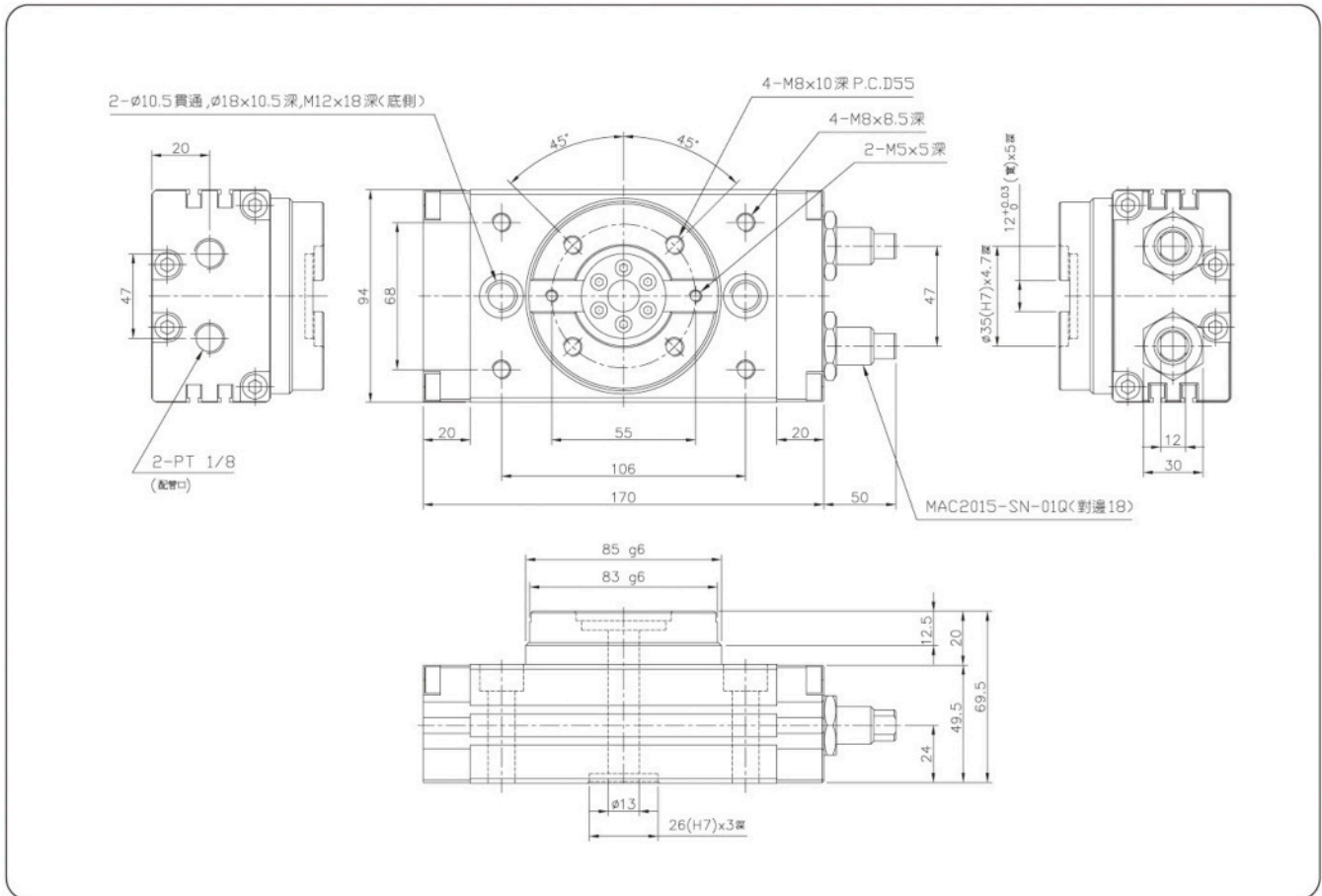

SRB-32

### (接觸式)C型槽感應器系統 (Contact) C-slot sensor system

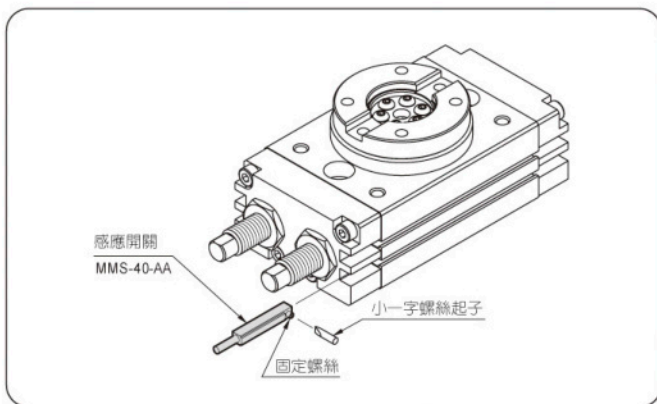

- 接觸式C型槽終端位置監控: 夾爪磁簧感應器, 安裝於夾爪C型槽內。
- 每個機械夾爪需要至少2個感應器(接觸式)。
- Contact C-slot terminal position monitoring: Gripper magnetic field sensor, installed in the C-slot.
- Each mechanical gripper needs at least two sensors (contact).

型號 Model	型式 Description	建議使用數量 Recom. number of use
MMS-40	直行設計 (兩線無接點) Straight design (two-line non-contact)	2

### 夾爪調速閥 Speed control valve

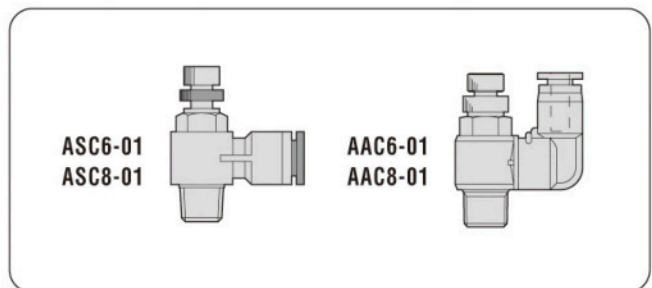

- 夾爪專用調速閥: 調整夾爪開張速度專用調速閥門。
- 每個機械夾爪需要至少2個調速閥。
- Speed control valve special for grippers: Special for adjusting the opening speed of gripper.
- Each mechanical gripper needs at least two speed control valves.

型號 Model	型式 Description	建議使用數量 Recom. number of use
ASC6-01	90度設計 $\phi 6$ 管徑 90 degrees design $\phi 6$ diameter	2
ASC8-01	90度設計 $\phi 8$ 管徑 90 degrees design $\phi 8$ diameter	2
AAC6-01	直通設計 $\phi 6$ 管徑 Through design $\phi 6$ diameter	2
AAC8-01	直通設計 $\phi 8$ 管徑 Through design $\phi 8$ diameter	2